



M.LARGE

UK & IRELAND FORESTRY EQUIPMENT DISTRIBUTORS



Product Guide
2016-17

Hakki Pilke Easy 38



UK and Ireland's No.1 range of firewood processors for professional, semi-professional and domestic users. Power options include tractor PTO, 3 phase electric and combi models. Chainsaw and TCT circular cutting options available. Contemporary design matched with reliability and safety.



Hakki Pilke Falcon



Hakki Pilke CS900/CS1000



With over 10 models to choose from, Hakki Pilke offer a safe modern and highly efficient range of firewood processing equipment for all levels.

Now introducing the new Hakki Pilke CS900/CS1000 range of professional heavy duty circular saw firewood processors.



Log Feeder Systems

Log feed racks, chain feeding tables and hydraulic log lifts to suit any machine in the firewood processor range.

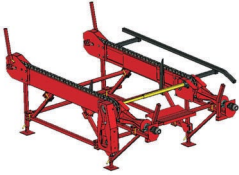

Hakki Feed 471



Hakki Feed 422



Hakki Feed 472

Drum screening

Hakki Pilke log cleaning drum for the separation of debris from split timber.

Electric motor or hydraulic power options.



Stump Grinders

The Carlton stump grinder range is one of the oldest established brands in the world. Well known for their unrivalled performance, high build quality, and cutting edge technology; the Carlton stands out as the professional's choice.

The 'Carlton Razor Cut' cutting system is installed on all self-propelled models as standard.

Below are the key benefits of the 'Carlton Razor Cut'

- Maximum Power to Cutting Head
- Deeper Cutting Sweep Reducing Time On Each Stump
- Simple Time Efficient Maintenance
- Cost Effective Compared To Other Systems



Carlton
PROFESSIONAL
STUMP GRINDERS

SP2010



Wide range of woodchippers from Greenmech and Farmi. Suitable for both green waste reduction and biomass woodchip fuel production. Tractor PTO, engine powered, road tow and self propelled track options available. Greenmech unique disc cutter blade system makes less noise, needs less maintenance and requires less power than other chippers.



Greenmech Arboret 150 Road Tow

26 or 34HP Kubota Diesel Engine
Disc blade chipping
Sub 750kg weight.



TMP 220 PTO



CS100



Safetrak 16-23

FARMI[®] FOREST

Farmi CH260/380 tractor PTO drive for brush reduction/ biomass fuel chip production. Simple design High output Low investment option



550 EH / SA

KGD offer an excellent range of skidding winches from a basic KGD 350 (3.5T) to a KGD 800(8t) electro-hydraulic . All winches are of clear robust design made from high tensile steel, fully powder coated for maximum corrosion resistance. After assembly each winch undergoes 100% pulling and brake force test which is fully documented before leaving the factory.

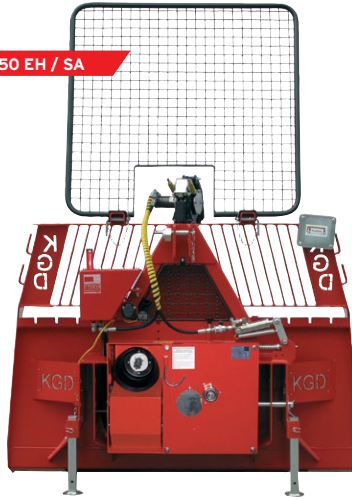

Standard Features:

- 3 year warranty
- Compacted cable
- Choker chains and keyhole slider
- Trailer hitch
- Chainsaw carrier

Options

- Radio control
- Hydraulic cable unwind
- Offering a range of gearbox winches



Grapples and Rotators

Stocking a wide and varied range of timber grapples, rotators and links. Suitable for timber cranes and excavators handling logs, brush etc. Rotators both free hanging and flat faced fixed.



Firewood Guillotines



Sole distributors for leading firewood guillotines from Bilke. Experience the simplicity and speed of a guillotine with its unique cut and split dual action. Ideal for first thinnings, coppice and waste wood. Processing speeds of up to 30 cubic metres per hour.



S3 PTO



Pilkemaster Smart 1

The PilkeMaster Smart 1 firewood processing unit is a unique tractor front loader, telescopic handler or excavator mounted attachment for picking up, measuring, cutting and splitting logs up to 190mm in diameter straight from the wood pile. Capable of processing the split logs directly into a trailer or bulk bags etc with no extra modification needed other than hydraulic flow and return which most loaders have fitted as standard. This makes for a safe, quick and labour saving firewood processor.

PILKEMASTER® SMART 1



Energy Grapples



Energy grapples are specially engineered forestry grapples designed for harvesting energy wood efficiently and rapidly. With built in grapple and cutting actions plus a range of options for bunching and de-limbing, energy grapples will make short work of thinnings and wood up to 300mm. Stocking energy grapples from renowned European manufacturers such as Biojack.

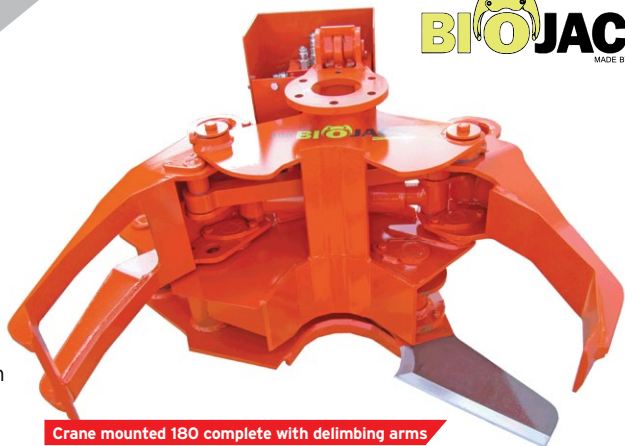

Crane mounted 180 complete with delimiting arms

Now one of the market leading forestry trailer and crane combinations in the UK and Ireland, renowned for high quality workmanship and durability. Offering a wide variety of option including custom built units.

Options:

2wd & 4wd

PTO independent hydraulic pump units

Operator control options

Bed extensions

Road lighting kit

Operator platform/high seat

Trailers from 3 - 15 tonnes

Cranes from 4 - 8.4m reach



10D & 695 complete with fold down support legs



Wheel and tyre varied size options



Operator high seat option

Exclusive importer and distributor for Nokka ATV trailers and loaders from Finland. Nokka products leverage the mobility of ATVs and bring loading and lifting power to wherever it's needed. Featuring hydraulically controlled frame extensions, Nokka on board engines, hydraulic 4WD, and loader cranes with telescopic support legs. Range of options include tipping bodies and clam shell buckets.



Forest Pro 1042 - 106HD



Flails & Mulchers

FERRI®

ICUT 4 flex



Radio controlled slope mower

The FERRI ICUT 4 radio controlled thrives in the toughest terrain, making it easy to work on busy highway embankments, railway sidings, steep-slopes, riverbanks, farmland, open park areas and site clearance. It ensures safe, productive working without risk to operator. FERRI ICUT 4 continues to expand its range of attachments, offering a tool for almost every challenge. From snow clearance to forestry brush clearance and grass cutting using heavy duty hammers for gorse and heavy shrub clearance. The FERRI ICUT 4 is fitted with a 50Hp Isuzu diesel engine to provide the extra power required for heavy duty work.

The FERRI ICUT 4 can provide a safe and productive remote control solution. An amazingly reliable and robust radio control slope mower which ensures optimal grip and traction thanks to its cutting edge design and attention to detail. ICUT 4 proves to be a real slope mower that allows you to work in perfect safety, with maximum performance working range up to 150m. The easy-to-learn remote control console allows the operator to safely work away from dangerous and difficult to reach areas, working on slopes up to 55 degrees in each direction with its low centre of gravity. This prevents risk of overturning.

Heavy duty 3 point linkage forestry mulcher:

Models to suit tractors from 60 up to 200Hp with an option of flails and fixed carbon teeth ideal for quickly clearing undergrowth, trees and stumps up to 400mm diameter.



TFC-DT/F2200 complete with hydraulic push over bar



TFC/R1800

Excavator mounted flails

Grass, brush and heavy duty forestry mulching excavator mounted flails.

1.5 to 20 ton + with options of swinging hammer flails and fixed carbon teeth

THM 125 complete with float linkage

TIR



TIR 150 complete with float linkage

THM



THM/F 160



Logsplitters



25 tonne Diavolik VPF - 46.B.PF



11 tonne Mignon - 23.223.PD



13 tonne Farmer Multiuse - 9Hp
Subaru engine - 37.M.V5.10.PD

Huge range of professional and domestic log splitters ideal for splitting large rings and tree trunks to manageable sizes. Splitting force from 4 - 30 tonnes. Thor range features the unique foot pedal "Leader" system. Power options include tractor or any other external hydraulic supply, PTO, single phase and 3 phase electric.



4 tonne ASP 4-370

ATIKA[®]

Kindling Machines

High value kindling wood production from timber offcuts and round logs. Kindling machines from Fuelwood are an essential complement to any firewood producer's equipment. Easy batching from output tray. Up to 400mm log diameter. Kindling output rate of up to 2.7 cubic metres per hour.

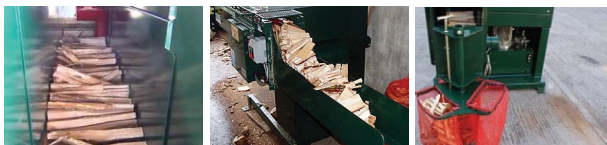

FUELWOOD
KINDLING MACHINES

AKM Pro 250



LMS 870/26t



The Woodbuster 870 will easily precleave oversized timber sections for further processing and features LMS Design's unique sweeper arms which prevent logs sticking on the cutting jaws.

LMS 440 Scorpion Excavator Mounted Tree Shear

The Scorpion 440 Tree Shear; a tree removal and shearing device to cut through trunks of up to 440 mm diameter in a matter of seconds. Make tree work more cost effective with the Scorpion 440.

The Scorpion 440 tree shear attaches to most excavators or teleporters and features built-in limb support and 25mm Hardox shearing blades.

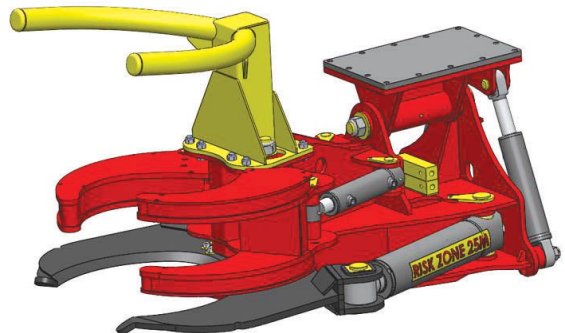

LMS 440 MK3 Scorpion



Northern Ireland dealer for the Atlas range of truck mounted loader cranes ideal for handling building materials; brick, block and grabs.

The long established Atlas brand guarantees supplier performance and long lasting reliability.

Offering - Sales, fitting and product service backup!

Accessories

Rotators and links from Baltrotor, log baggers and grapple adapters for loader tines and three-point-linkages from own brand LMS Design. Wide range of accessories to enhance capacity and capability of forestry equipment.



LMS log baggers and grapple adapters for loader tines and three-point-linkages from own brand LMS Design. Wide range of accessories to enhance capacity and capability of forestry equipment.



Why buy from M. Large

M Large is a long established company specialising in a wide and varied range of timber harvesting, handling and processing equipment. Items highlighted in the 2016-2017 product guide are only a sample of what we hold in stock. Alongside new we offer and carry a range of shop soiled, ex-demo and second hand fully serviced equipment.

M. Large adhere to all guidelines issued by the health & safety bodies and have a proven track record of offering excellent quality equipment that meets all current safety legislation. We are one of the few suppliers in our industry to have both ISO 9001 quality management and ISO18001 Health & Safety management systems in place. All machines supplied by M. Large are fully CE compliant.

With the help of our extensive nationwide dealer network, we offer exceptional value for money and an excellent back up service. Our vast stock of spare parts are available for next day delivery and with the expertise of our sale engineers we can provide advice and assistance to both new and existing customers. Many of the products that we sell are also used by our contracting division on a daily basis which gives us a true insight into how the equipment performs.

Speak to us about finance, current discounts and special offers.

For further information/prices or to view one of the biggest ranges of Forestry Equipment in Europe, please ring us on:- ++44 28 9034 2838 or visit our web site www.mlarge.com Our knowledgeable and friendly team will be happy to help and discuss options that will suit your individual requirements.



Service

M.Large's experienced and proficient staff are always on hand to offer friendly service to customers and keep machinery working at it's optimum efficiency. Our in-house service team deal with warranty and post warranty enquiries to ensure customers of an end to end support service.



Parts

Wide selection of parts and spares for all stocked machinery and equipment, most available and delivered within 24-48 hours from order. Highly experienced service personnel to ensure customer machines are running smoothly and efficiently.

Notes



Suppliers of:



M. Large Tree Services Ltd. "Coolewell", Church Road, Newtownabbey, BT36 6DH

T. +44 (0)28 9034 2838

E. sales@mlarge.com

W. www.mlarge.com

Find us on Facebook

Follow us on Twitter

Watch us on YouTube

