

Cayvol HOOKLOADERS

from **ATLAS**[®]

The Perfect Partnership

From 3.5T to 32T GVW

plus 30T lift Semi Trailer Hookloader



MV-25/65

*CAYVOL QUALITY, PERFORMANCE
AND RELIABILITY BACKED BY ATLAS
SALES, SERVICE AND SUPPORT*

The Perfect Solution For

Following the appointment of Atlas Cranes UK as Cayvol's exclusive importer and distributor of Cayvol skiploaders, you now get the best of both worlds. The quality, performance and reliability of a market leading range backed by a nationwide sales, service and support network that is recognised and respected as one of **THE BEST IN THE BUSINESS!**



Match this with Cayvol's unrivalled range of proven, high performance hookloaders capable of handling a wide variety of different and demanding applications, and you have at your disposal a powerful combination of resources, experience and expertise that's geared to delivering and supporting a product for virtually any job in any environment.

The 'COMPLETE' Range

- *In house design using Cutting Edge computer design programmes*
- *High quality steels with high elasticity limits giving reliability + durability.*
- *Super strength with Low system weights.*
- *Pneumatic in-cab controls for all functions.*
- *Low system height for better handling and stability.*

The range

• MV-3AG	3T lift	(Articulating Column)
• MV-5AG	5T lift	(Articulating Column)
• MV-9	9T lift	
• MV-15	15T lift	
• MV-18	18T lift	
• MV-22	22T lift	
• MV-25	25T lift	
• MV-30	30T lift	
• SRMV-3084	30T lift	Semi Trailer Hookloader.



perfection • reliability • peace of mind

Handling Bulk Waste

MULTIVOL MV-25/65 HD UK

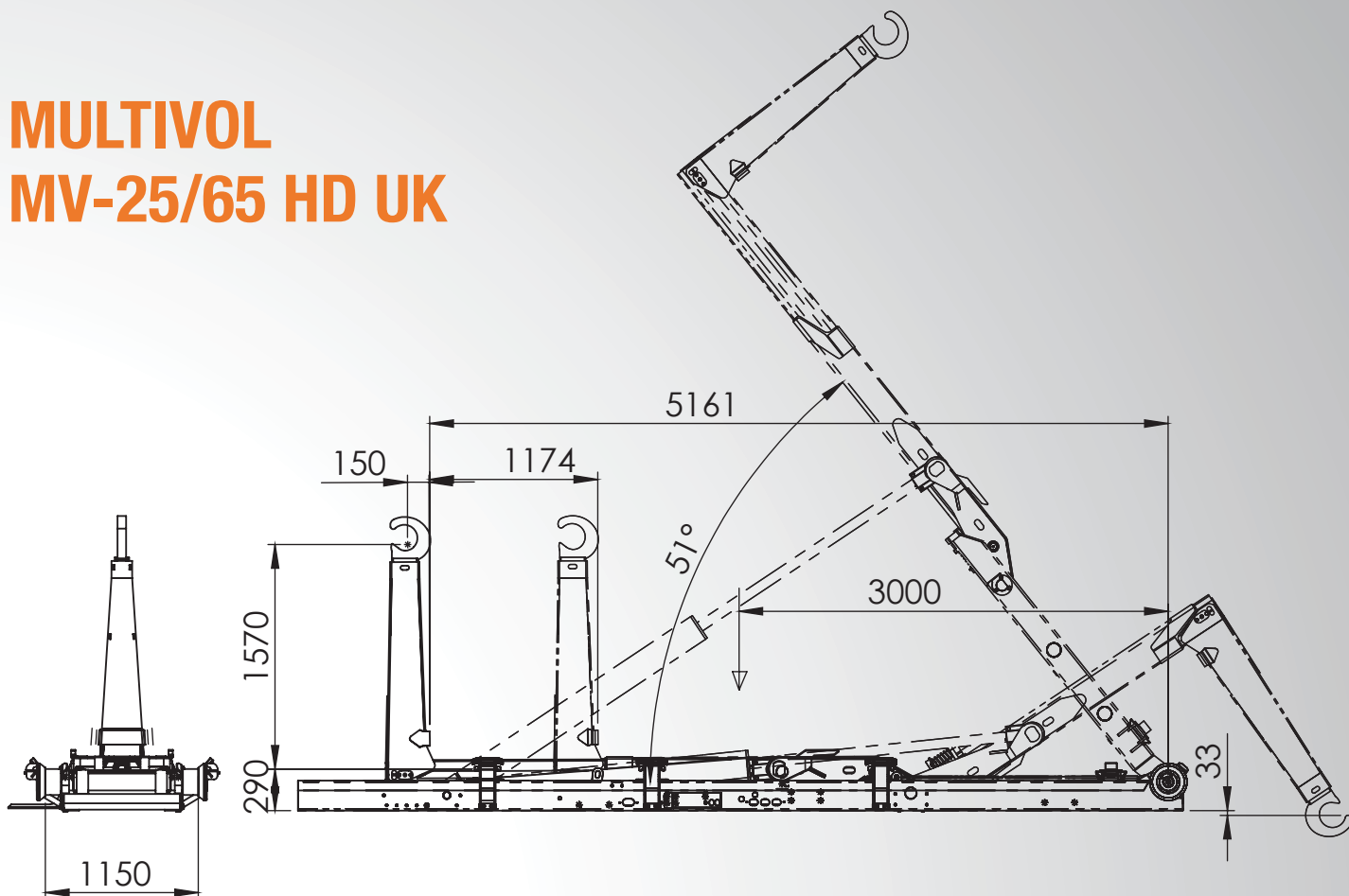

Technical characteristics

Tip angle 51°

Weights and capacities*

System weight 2450 kg

Load capacity (container included) 25000kg`s

Without consider vehicle stability

Hydraulic system

Oil flow required (at 1000r.p.m.) 75l/min

Maximum operating pressure 330 kg/cm

Oil flow required is not referred to pump size, but to the recommended flow at valve block entrance

Oil tank capacity 100 l

Working times (values at 1000 r.p.m.)

a) Tip time 49 s

b) Load time 38 s

Vehicle

G.V.W. 26000 kg

Wheelbase 1st to 2nd entre 1° y 2° eje 3800 a 4300

Containers

Minimum length 4500 mm

Maximum length 6500 mm**

Approximate values. Subject to axle calculation.

(*) DATA TO THE DEVICE WITHOUT INSTALLATION DIMMENSIONS QUOTED WITHOUT COMMITMENT.

(**) LIMITED the REGULATION ANTIEMBEDDING IT FILES HOLDS To MODIFICATION WITHOUT PREVIOUS WARNING