

TIGERGRIP | TG 25S

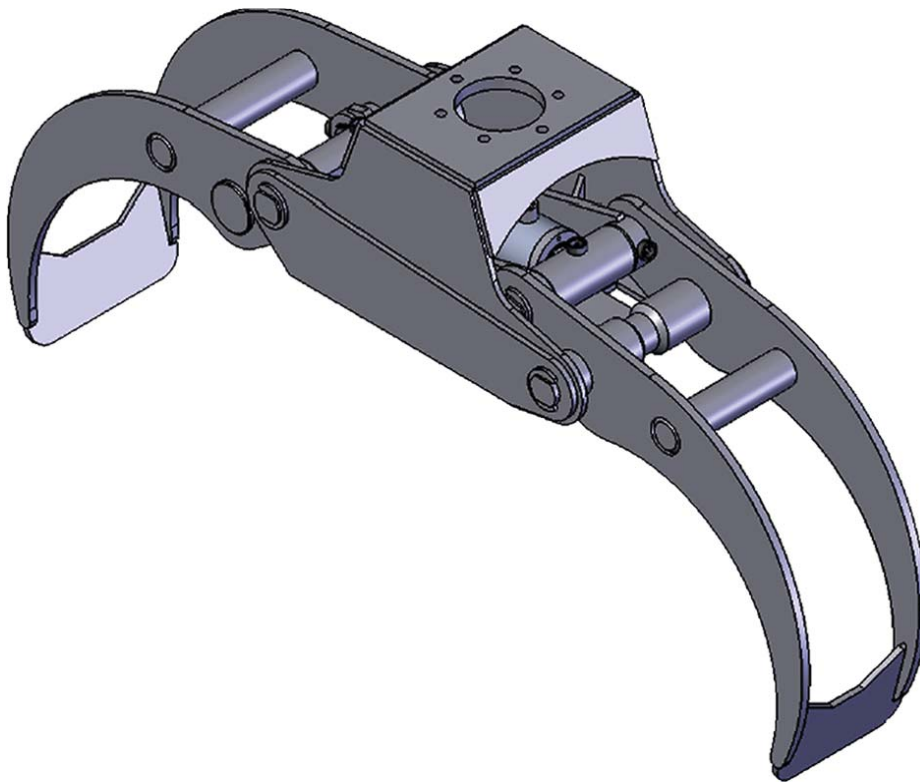

KEY FEATURES

- Heavy duty
- Double guide bars
- Optimized roll in/roll out properties
- High pressure cylinder with double piston rod seals
- High tensile wear resistant steel (400 HB)
- Extra reinforced body for rigid mounting - excavator design

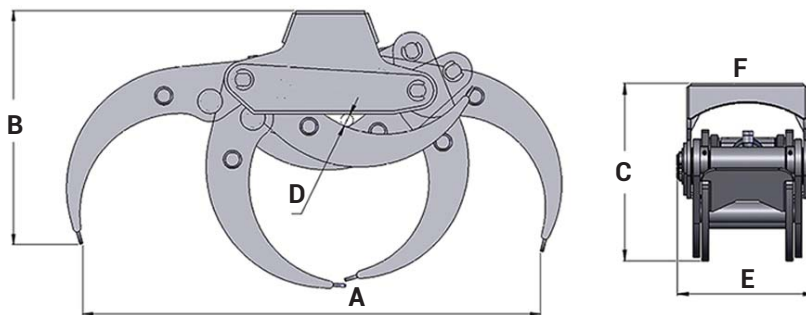

A	1450
B	746
C	508
D	40
E	390
F	173/6

MODEL SPECIFICATIONS



TG 25S	171	0,25	250	50	11	6	3	8	4	15		
--------	-----	------	-----	----	----	---	---	---	---	----	--	--

INTERMERCATO

High performance lift and load attachments for Forestry, Transport, Construction and Recycling.

