

# TIGERGRIP | TG 25

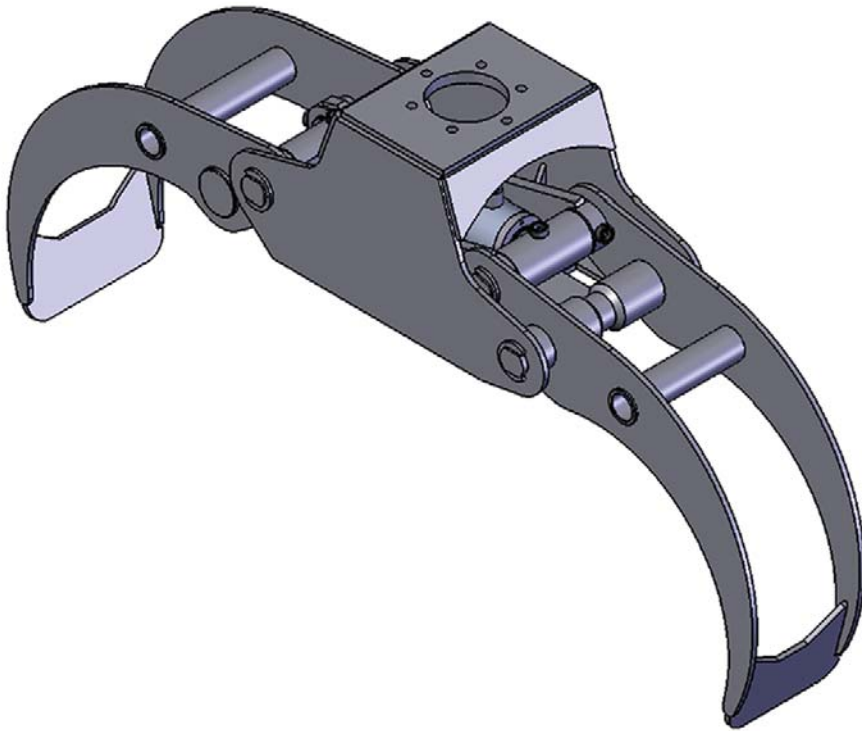

## KEY FEATURES

- Double guide bars
- Optimized roll in/roll out properties
- High pressure cylinder with double piston rod seals

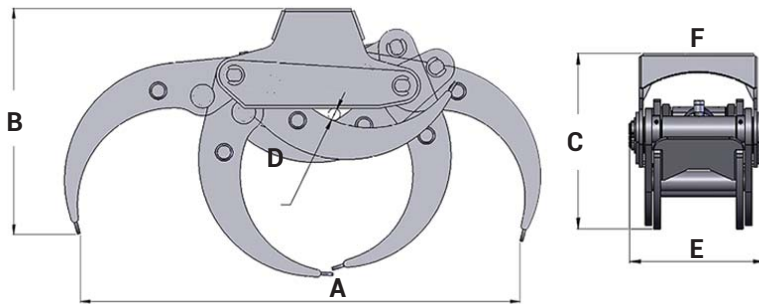

|          |       |
|----------|-------|
| <b>A</b> | 1450  |
| <b>B</b> | 746   |
| <b>C</b> | 508   |
| <b>D</b> | 40    |
| <b>E</b> | 371   |
| <b>F</b> | 173/4 |

## MODEL SPECIFICATIONS



TG 25

138

0,25

200

50

11

3

2

# INTERMERCATO

High performance lift and load attachments for Forestry, Transport, Construction and Recycling.

