

USER MANUAL

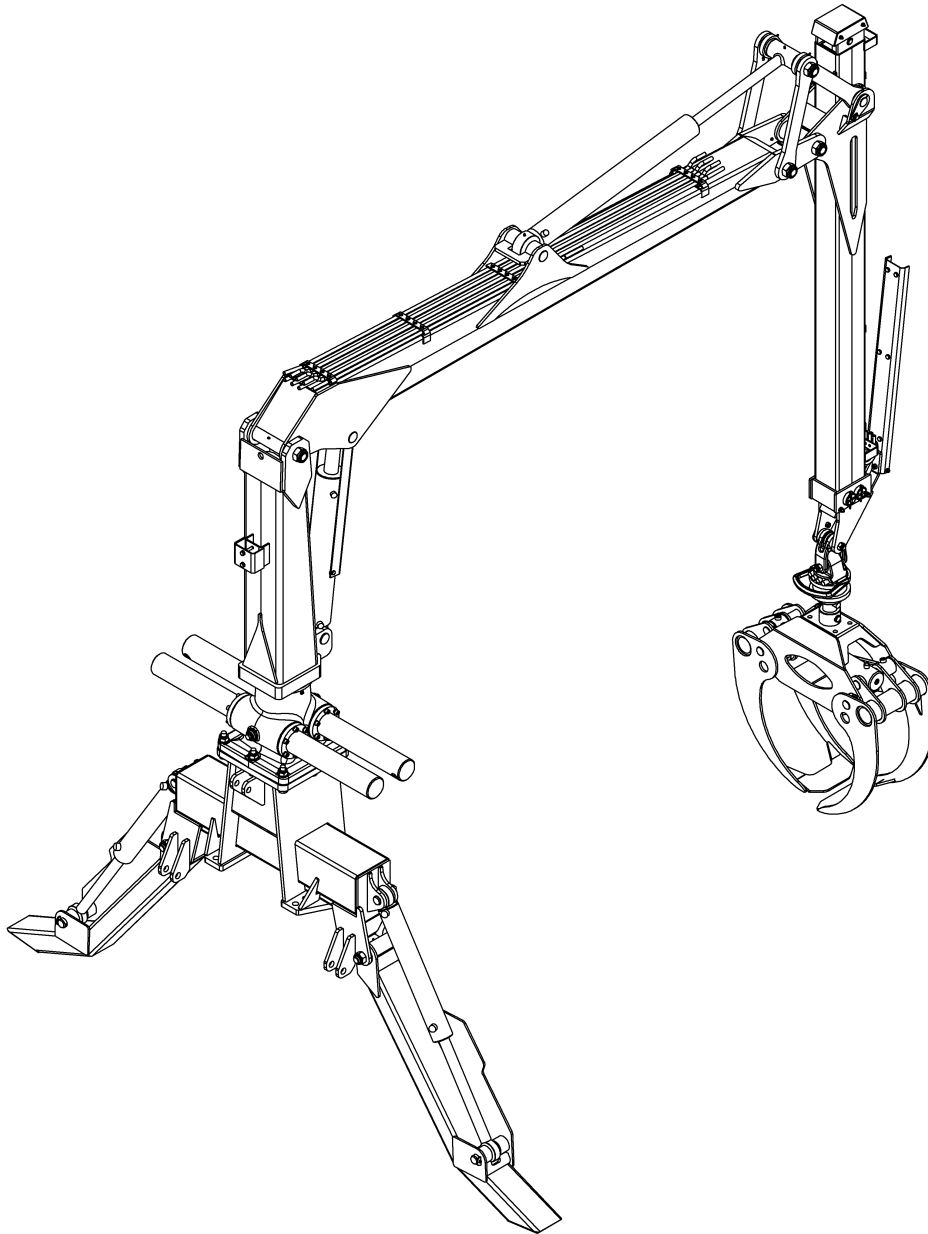

FOREST CRANE PALMS 700

Palmse Mehaanikakoda, Võsupere küla, Vihula vald, Lääne-Virumaa 45202, Estonia.
tel. +3723255375 fax +3723255378 e-mail: info@palms.eu <http://www.palms.eu>

TABLE OF CONTENTS

1. GENERAL.....	1
2. SAFETY	2
3. TECHNICAL DATA	5
4. ASSEMBLY AND MOUNTING	8
5. HYDRAULIC SYSTEM	12
6. OPERATING INSTRUCTIONS	22
7. DETACHING FOREST CRANE.....	24
8. STORAGE INSTRUCTIONS.....	24
9. MAINTENANCE.....	25
10. TROUBLESHOOTING.....	29
11. SPARE PARTS.....	30
12. WARRANTY	34

1. GENERAL

This manual gives you a detailed overview about forest crane **Palms 700**. Read the manual carefully before you start using this machine. The manual contains essential directions for efficient and safe use of this equipment. These instructions should always be followed. This forest crane is constructed for loading works in forestry and agriculture. It can be mounted on Palms forest trailers by unified connection. This forest crane has three point linkage system, by which it can be connected directly to agricultural tractors. This machine meets all technical standards and safety regulations of EU Machinery Directive and its amendments. Palms forest crane has CE marking.

Operator of forest crane is obliged to be aware of and strictly follow all safety precautions and instructions described in this manual.

In addition to this, instructions of local occupational safety authorities, as well national laws and regulations, must be followed.

Even if you are experienced user of this equipment, do not use it unless you have read the user manual.

Using the machine for other tasks than those for which it is intended or exceeding its performance is not allowed.

The manufacturer/dealer is not responsible for damage caused by misuse of the forest crane.

Pay attention to regular maintenance. In case there will occur problems with forest crane, which are not covered in this manual, contact authorized dealer or manufacturer.

Palmse Mehaanikakoda LLC reserves the right to make changes to user manuals and to revise the data without prior notice.

2. SAFETY

2.1 General

Read the manual carefully before you start operating this forest crane. Use forest crane only for right purposes. The operator must have a proper valid licence to work with the tractor and the forest crane. The operator has to have sufficient training prior using of this machine.

Notice, avoid and prevent all potentially hazardous situations!

IT IS STRONGLY FORBIDDEN:



- to use forest crane in state of intoxication by alcohol, drugs or other psychoactive substances.
- to exceed maximum loading values.
- to leave the load in UP position without supervision.
- to use forest crane for lifting people.
- to rebuild forest crane.
- to use repairing materials without the producer's permission.
- to localize a leakage from hydraulic hoses or connections by hand.

BEFORE YOU START OPERATING FOREST CRANE, MAKE SURE THAT:

- crane is in working condition.
- you have full visibility over all the working area.
- crane is placed firmly on even ground.
- the tractor parking brake is engaged.

IT IS RESPONSIBILITY OF THE USER:

- to ensure that attachments and connections to the vehicle are designed and adapted in such a way that they meet the crane's needs according to technical data.
- to install a loose crane on equipment other than a Palms trailer such way that the vehicle has the necessary capacity to cope with the lifting and slewing torques that the crane is designed to handle.

2.2 Safety distances



General safety distance for working with forest crane is 20 metres!

Follow special safety distance when working close to live electrical conductors:

Rated voltage, kV	Safety area, m
Up to 0,5	2
Up to 20	10
35 – 110	25
220 – 330	40

Table 1. Safety area

All electrical conductors must be clearly visible while operating the forest crane.

2.3 Hydraulic system



- Hydraulic system must be serviced by qualified and experienced hydraulics mechanic only.
- Continually inspect the condition of hydraulic system. Repair all safety en-dangering defects immediately.
- Before hydraulics maintenance work make sure that the system is not under pressure.
- When replacing hydraulic components and hoses, use original spare parts or parts recommended by the manufacturer.
- When performing maintenance work, use safety goggles and gloves.
- Prevent oil dripping to the ground in order to avoid environmental pollution.
- When working in ecologically sensitive areas, use bio-oil.

2.4 Operation



- Ensure, that forest crane is in good working condition.
- Operating with damaged or defective machine is prohibited.
- Ensure, that you have best possible sight and control over the working area.
- Prevent unauthorized persons access to the working area.
- Support legs must be used while working with forest crane.
- Be sure not to endanger anyone while lowering support legs.
- Pull support legs up before moving the tractor.
- Use tractor parking brake during working with forest crane.
- Do not use equipment, which is not recommended by manufacturer.
- Never lift heavier load, than allowed by the manufacturer.
- When leaving the machine, always secure it from unauthorized access and unintended operation.
- Manufacturer is not responsible for any damage or loss, that is caused by misuse or incorrect, careless, unauthorized and inappropriate use of the machine.
- Follow the traffic regulations while driving on public roads!

3. TECHNICAL DATA

3.1 Dimensions of the forest crane

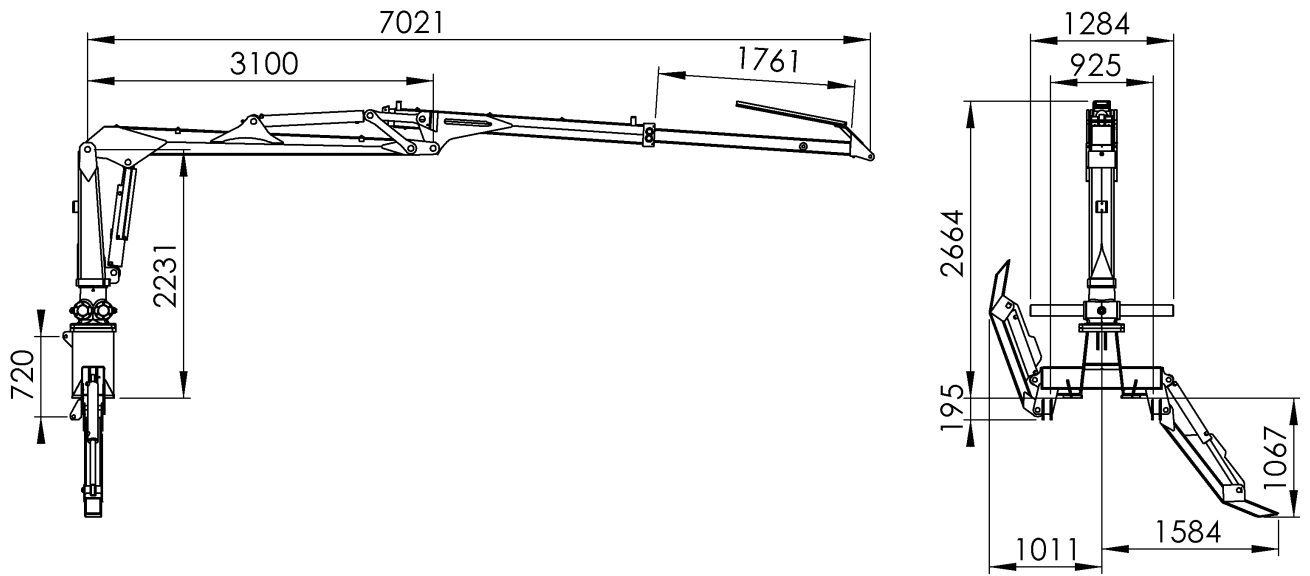

Figure 1. Palms 700 dimensions (mm)

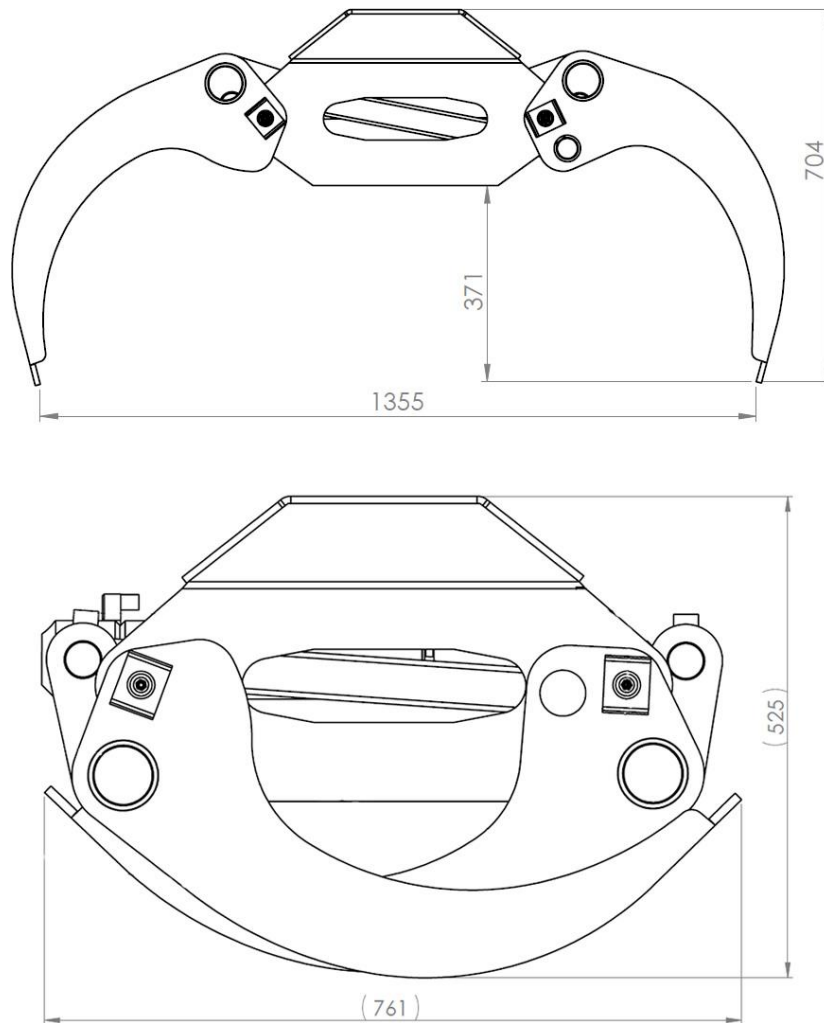

Figure 2. Grapple 0,215 Pro dimensions (mm)

3.2 Lifting reach

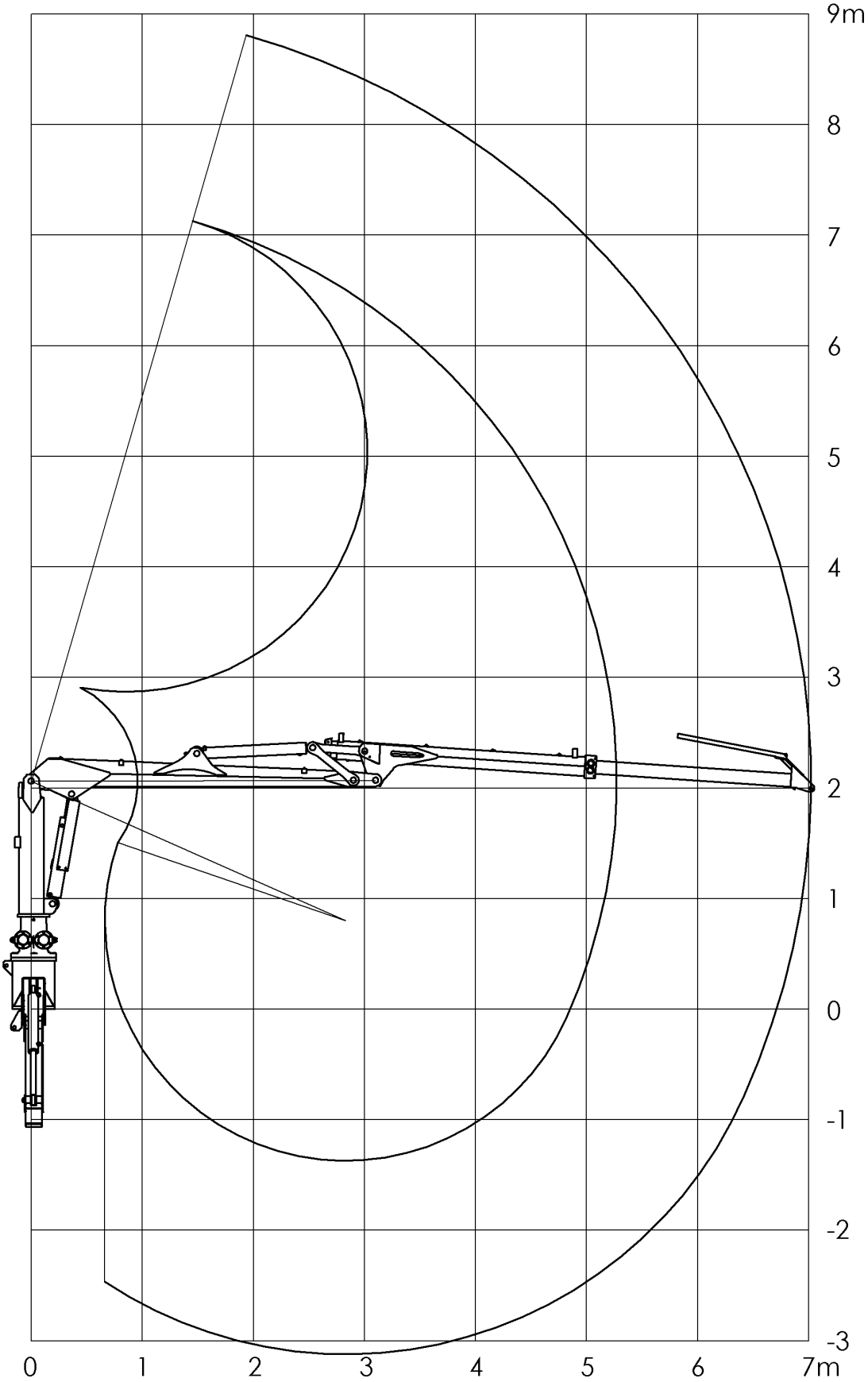

Figure 3. Lifting reach of Palms 700 forest crane

3.3 Technical data

Max reach	7,0 m
Lifting torque, kNm, bruto	62 kNm
Lifting power on 4m without grapple and rotator	1150 kg
Lifting power on full reach without grapple and rotator	660 kg
Grapple	0,22 m3
Rotator	GR 46
Grapple and rotator weight	135 kg
Slewing torque	16 kNm
Slewing cylinders	4
Boom rotation	370°
Hydraulic valve, standard	NH 6/8 XY
Working pressure	180 bar
Hydr pump capacity, l/min	70 l/min
Total weight	1500 kg

Table 2. Technical data table of Palms 700

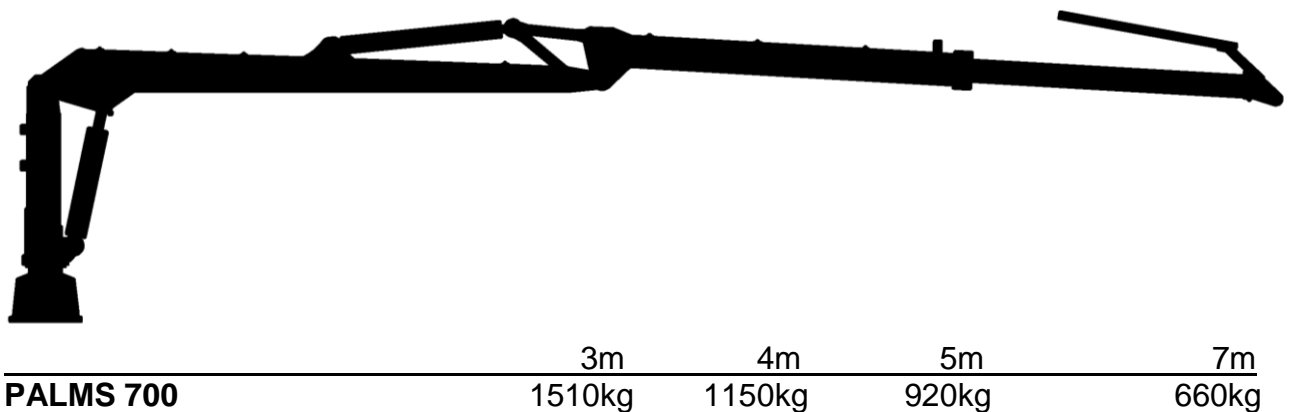

Figure 4. Palms 700 lifting power on different distances

Manufacturer reserves the right to change specifications without prior notice.

4. ASSEMBLY AND MOUNTING

Read these instructions before starting any assembly or mounting of crane. Improper mounting, carried out in a manner other than specified in this manual, may cause dangerous situations to user and surrounding objects. Improper mounting, useage and installations will void the manufacturer warranty.

4.1 Mounting forest crane to Palms trailer

Mounting of forest crane should be performed at the dealer service center or by person authorized by the manufacturer or dealer. Mounting/detaching the crane can also be made by end user, if professional equipment is used, all safety regulations are followed and at least one qualified mechanic is present during all the mounting/detaching process. Strength class for mounting bolts of slewing device-support legs (pos. 1, fig.5) and support legs-trailer (pos. 2, fig. 5) has to be 12.9 (DIN912). Use self-locking nuts M24. The tightening torque for the mounting bolts of the crane (pos. 1, fig. 5) and supporting legs (pos. 2, fig. 5) is 1220 Nm.



Retighten bolts after the test run and after first 8 hours of use! Check after 40 working hours, tighten if needed. Visual check is required prior every working session.

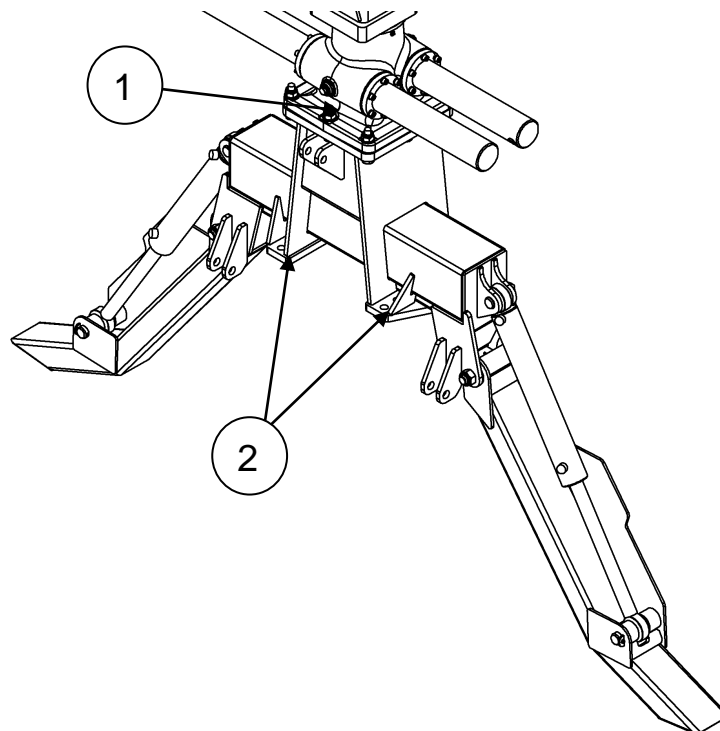

Figure 5. Connection junctions on Palms 700 support legs

4.2 Mounting forest crane to the other manufacturer's trailer or to any other machine than Palms forest trailer.

Use the mounting plate (fig. 6) then mounting the loader to the tractor's frame or trailer different than Palms. Use mounting plate with thickness not less than 30 mm. Make sure that there will be enough space at mounting point for service access.

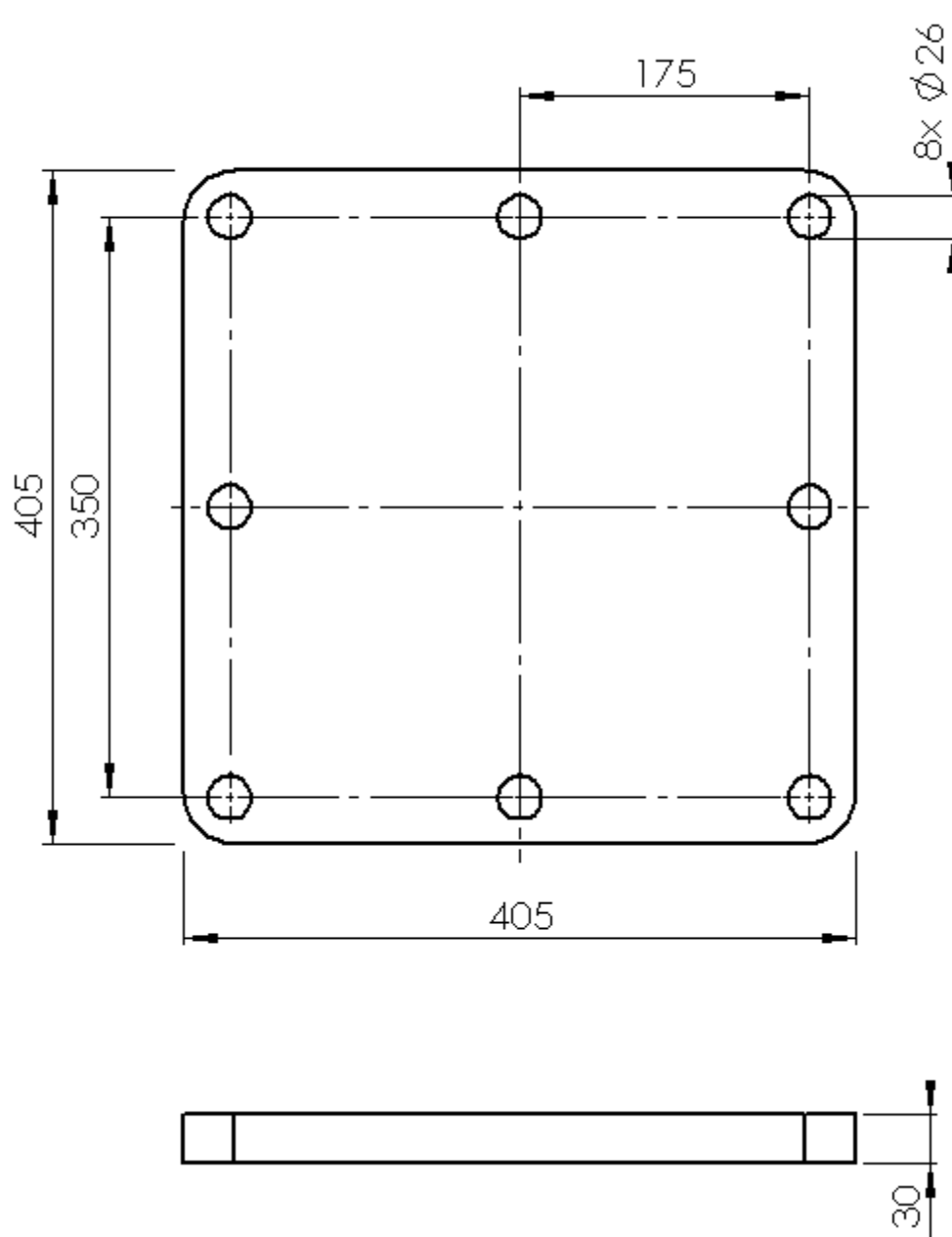

Figure 6. *Mounting plate measures*

4.3 Mounting forest crane to the tractor with 3-point linkage system

Before mounting crane to the 3-point linkage (pos.1, fig. 6.1) make sure that:

- tractor is heavy enough and will not keel over
- tractor is placed firmly on even ground
- tractor 3-point linkage equipment is in working condition
- hydraulic hoses and couplings are not damaged
- there is enough oil in tractor hydraulic system

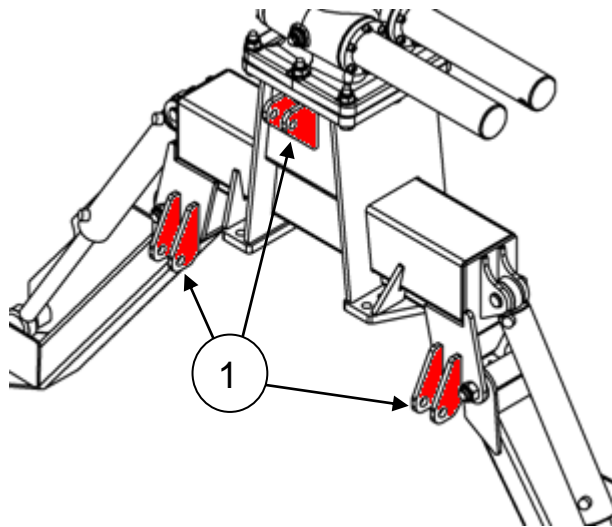

Figure 6.1 3-point linkage junctions on FD support leg (B6)



Do not use hydraulic puller for connecting upper junction of 3-point linkage!

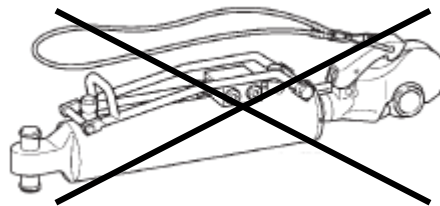

Figure 6.2 Hydraulic puller

4.4 Mounting control valve



The valve must be installed in the way that levers cannot be used inadvertently!

Install the valve to desired location using the included bracket. Leave enough space for hoses to avoid risk of abrasion or clamping while working with forest crane.



Hoses in the operator's cabin must be covered in the way that the user is protected from the direct oil jets in case of hose breakage!

5. HYDRAULIC SYSTEM

5.1 Connection

Before connecting forest crane to the tractor's hydraulic system, make sure, that hydraulic oils are compatible. Forest crane has been tested and should use Addinol HVLP 32 hydraulic oil or other compatible oil that meets DIN 51524-3 requirements. Check level of hydraulic oil. We recommend connecting the pressure hose to the single-acting hydraulic outlet and the return hose to the tank via the return filter. Intended minimum flow rate for filter is 70 l/min and the filtering density is 10-50 µm.

Make sure the connection has made properly.



In order to avoid valve damages, always connect hydraulic hoses according to user manual!

Make sure you connect the return line, bolder hose, always first and disconnect it last.

Ensure, that the control valve pressure line, thinner hose, P has been connected properly and that the return line, bolder hose, T is not obstructed.



In case there is obstruction in return line (quick couplings are not connected or are not locked properly) the pressure might rise over 10 bar and cause malfunction of control valve.

Forest crane can be also connected to the double-acting hydraulics outlet. If this option will be used, make sure, that the lever of the double-acting valve is in the right position and the pressure is directed to the pressure connection of the crane's control valve. Check also vehicle's operating manual for hydraulic system connecting instructions.

If your crane has pilot operated valve control with pilot operated TP return line installed, TP return line has to be connected straight to the hydraulic oil tank. Pilot operated TP line hose has 1/4" size connection fitting. Some vehicles have separate quickcoupling installed on hydraulic oil tank, which you can use for pilot operated TP line, some of them do not.

Pilot operated TP return line can not take more than 6 bar of backpressure!

Do not connect pilot operated color TP line in to the main return line!

If crane is not used, leave pilot operated TP return line open. Do not close TP return line with regular plug fitting. Pressure can build up and damage valves.

5.2 Parker hydraulic diagrams and control functions

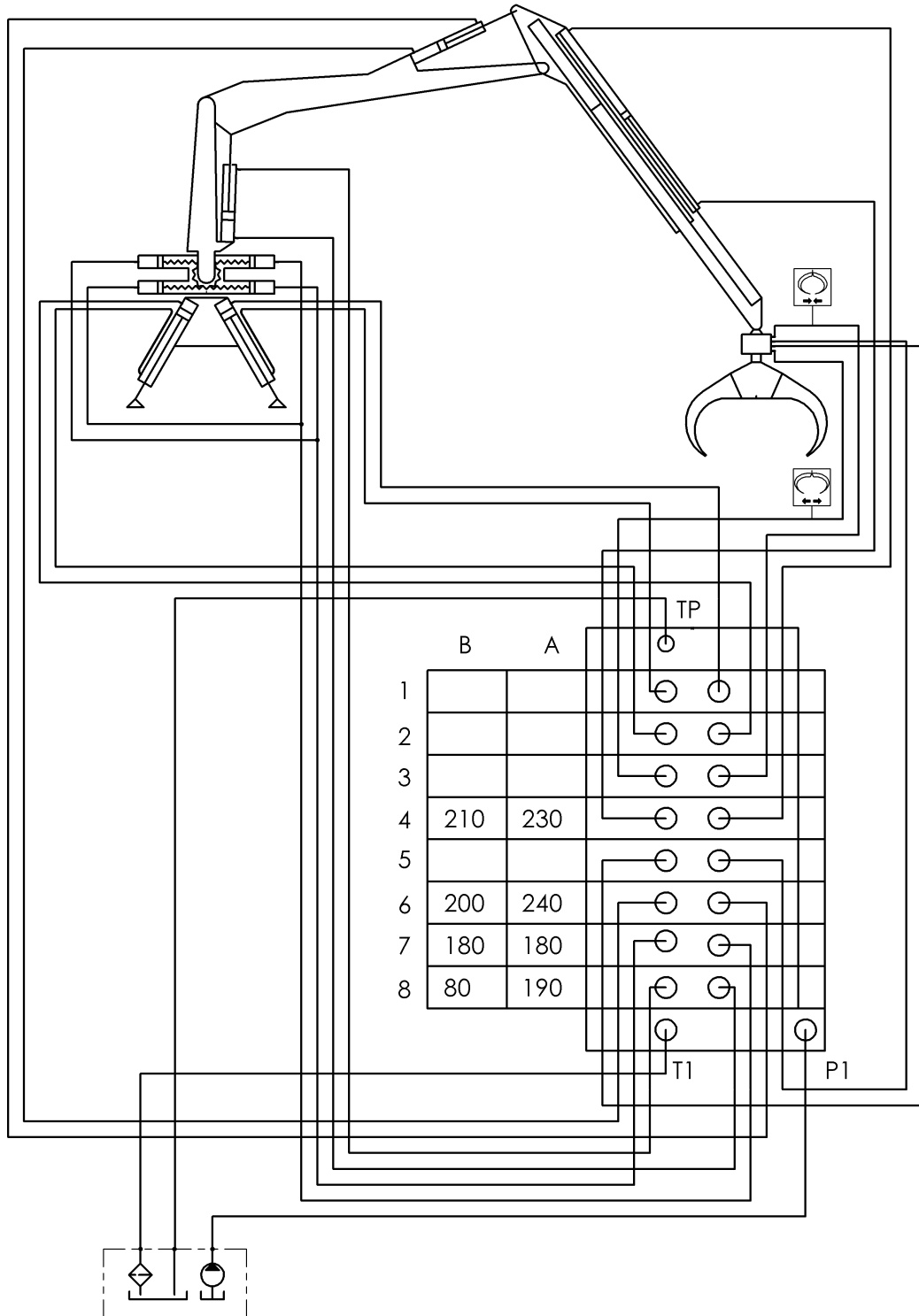

Figure 8. Hydraulic diagram for Parker L90LS (A23 and A24) full electric control valve

A21/A23 Full electric valve
electric schema

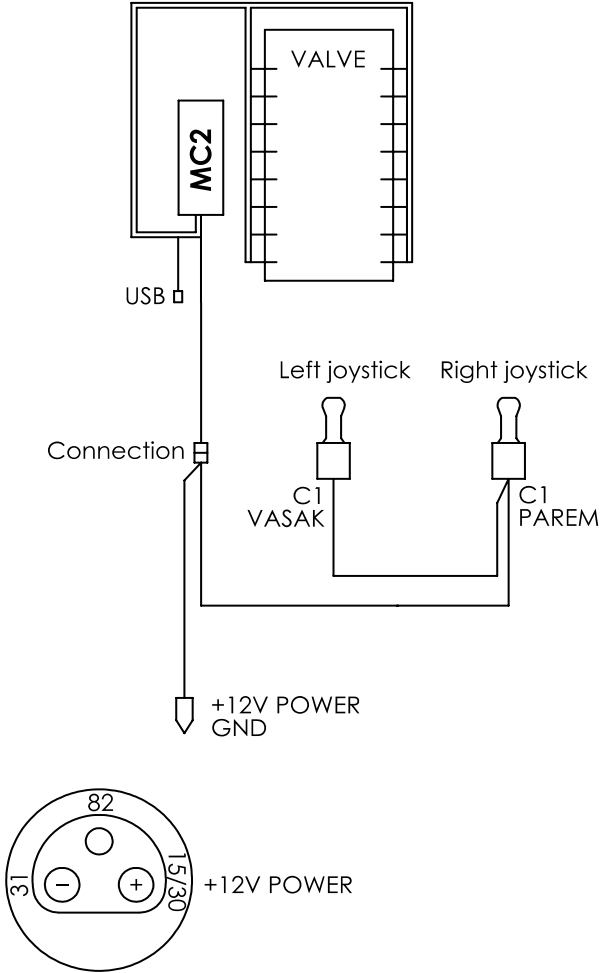

Figure 9. Electrical scheme for full electric control valve (A21 and A23)

A22/A24 Full electric valve with display
electic schema

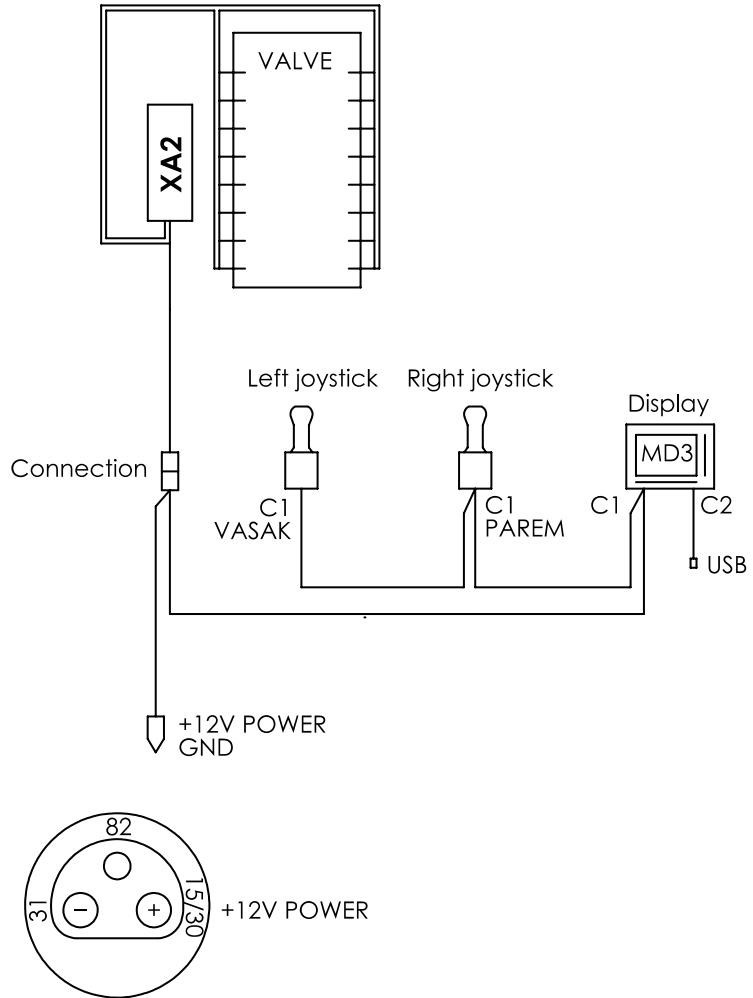
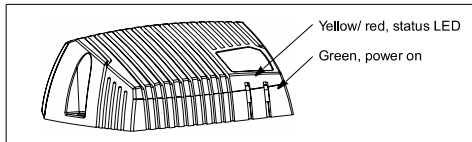
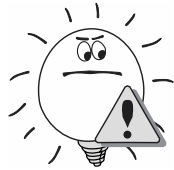

Figure 10. Electrical scheme for full electric control valve (A21 and A23)

Appendix B

Error codes, messages and actions

If one of the following error is detected, a message will be presented on the display together with an error code on the module. In some cases, the module will turn off or at least shut down the outputs, to increase safety.



The location of the LED indicators on the IQAN-MC2 module.

OBSERVE

Don't use the machine if an error message or error code is activated.

The following sections will present what measures to take for different error situations put into appropriate context.

LED indicator showing different MC2 modes

Status	Flash (yellow)
Normal operation	
Application not loaded	
No application available	
Bad application	
Busy	

Error code	Error	Primary Flash (red) Error category	Secondary Flash (yellow) Error description
1:1	Output		
1:2	Input		
1:3	Vref		
2:1	Power Supply		
2:2	Temperature		
2:3	Clock		
3:1	CAN error		
3:2	Address error		
4:1	Internal error		
SCS	Safe Crash State		

Figure 11. Error codes and messages for *full electric control valve (A23)*

Appendix B

Error codes, messages and actions

If one of the following errors are detected, a message will be presented on the master display together with an error code on the module. In some cases, the module will turn off, to increase safety.



WARNING

Do not use the machine if an error message or error code is activated.

The following sections will present the possible error codes and what measures to take for different error situations put into appropriate context.

LED indicator showing different IQAN-LC5-C0x modes

Status	Blink (yellow light)
Normal (no errors)	

Status	Blink (red light)
Safe state (red)	

Error code	Error	Primary Blink (red) Error category	Secondary Blink (yellow) Error description
1:1	VREF error		
3:1	CAN error		
3:2	ADDR error		
4:1	Internal error		

VREF ERROR

Situation	Error code	Action LC5-C01	Comment
VREF < 4,75 V	Error 1:1	-	Check voltage
VREF > 5,25 V	Error 1:1	-	Check voltage

Figure 12. Error codes, messages and actions for IQAN – LC5 module

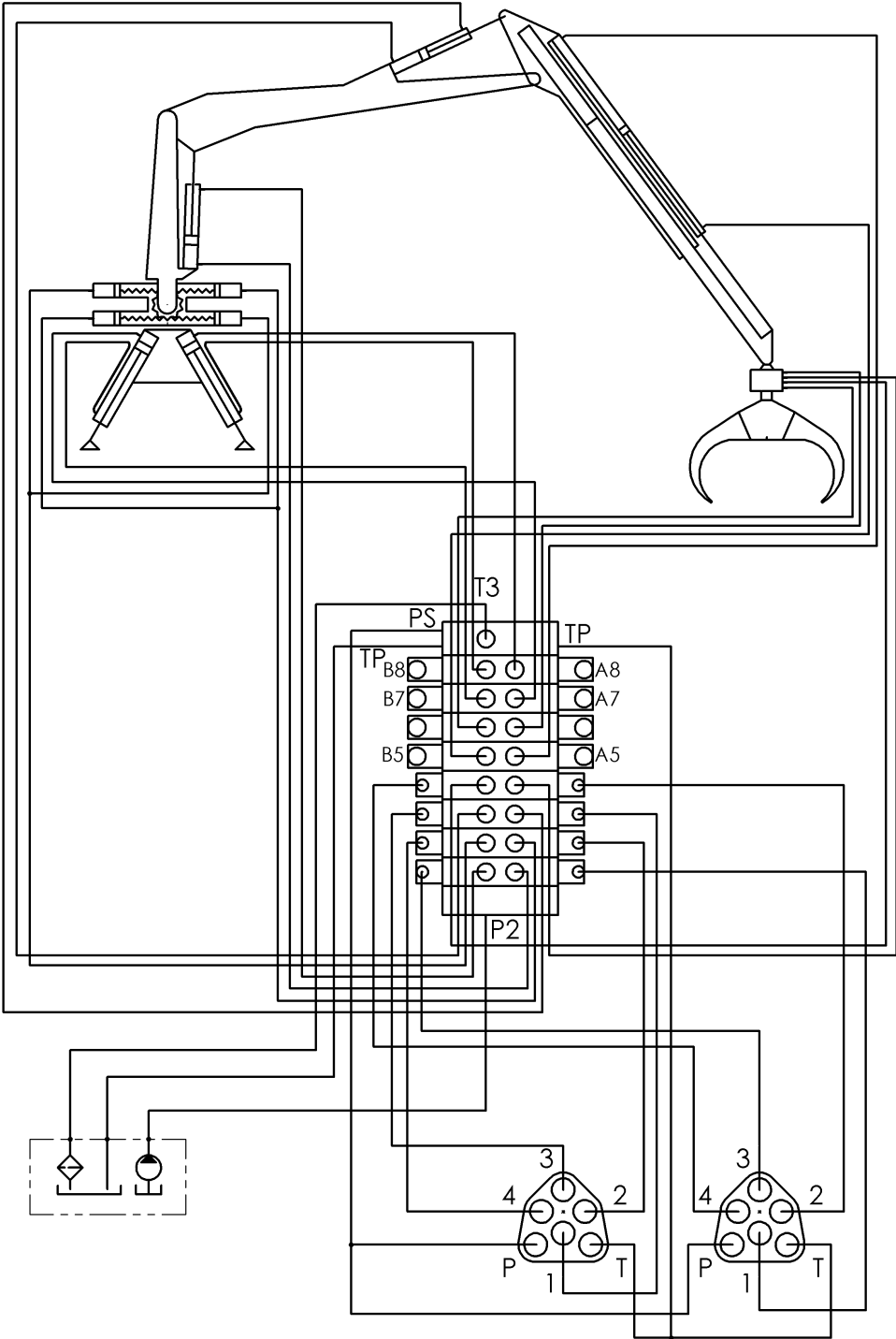

Figure 13. Hydraulic diagram for Parker F130 CF (A13) pilot operated control valve

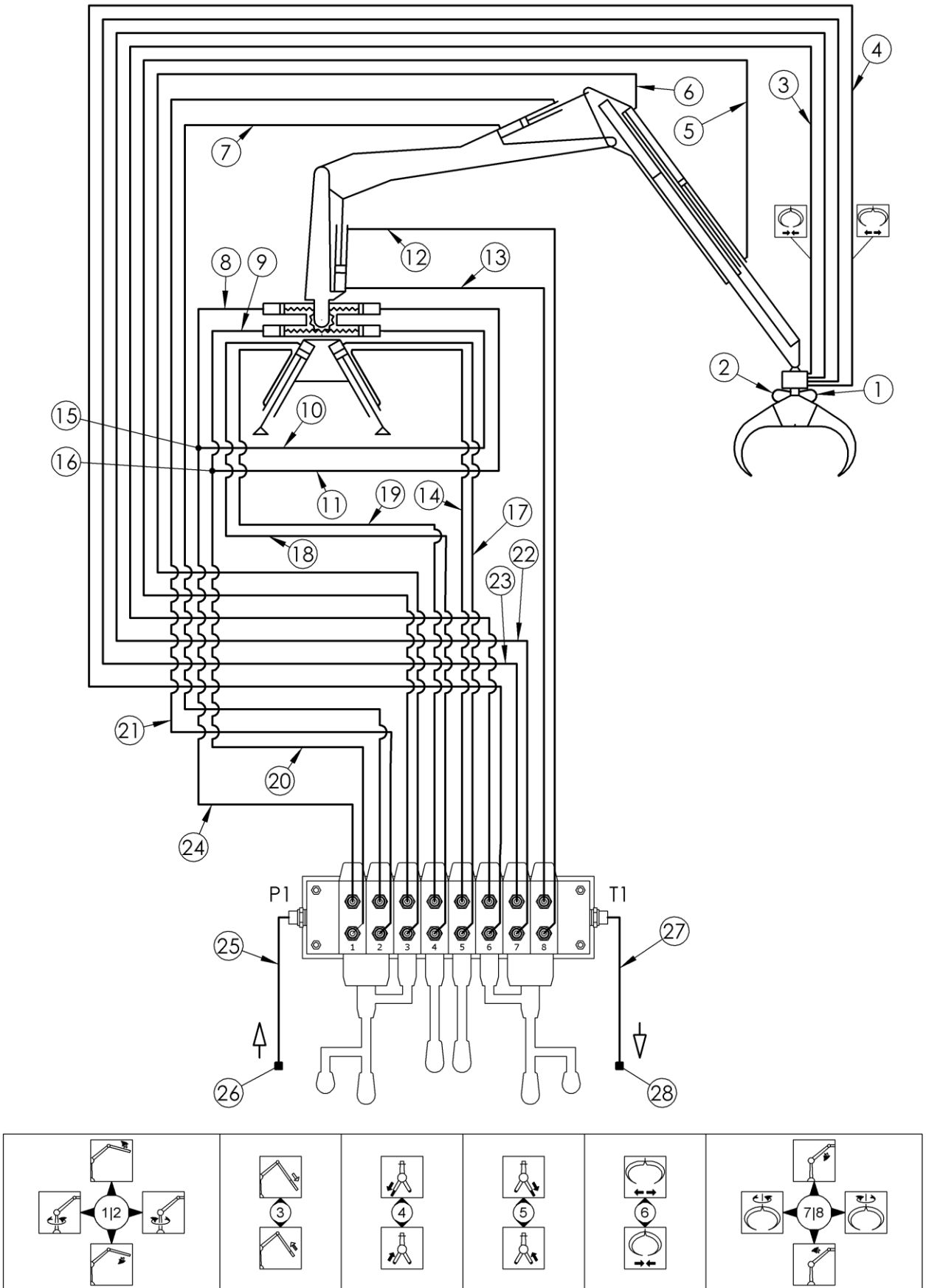

Figure 14. Hydraulic diagram for Nordhydraulic NH 4/8 XYZ (A7) control valve

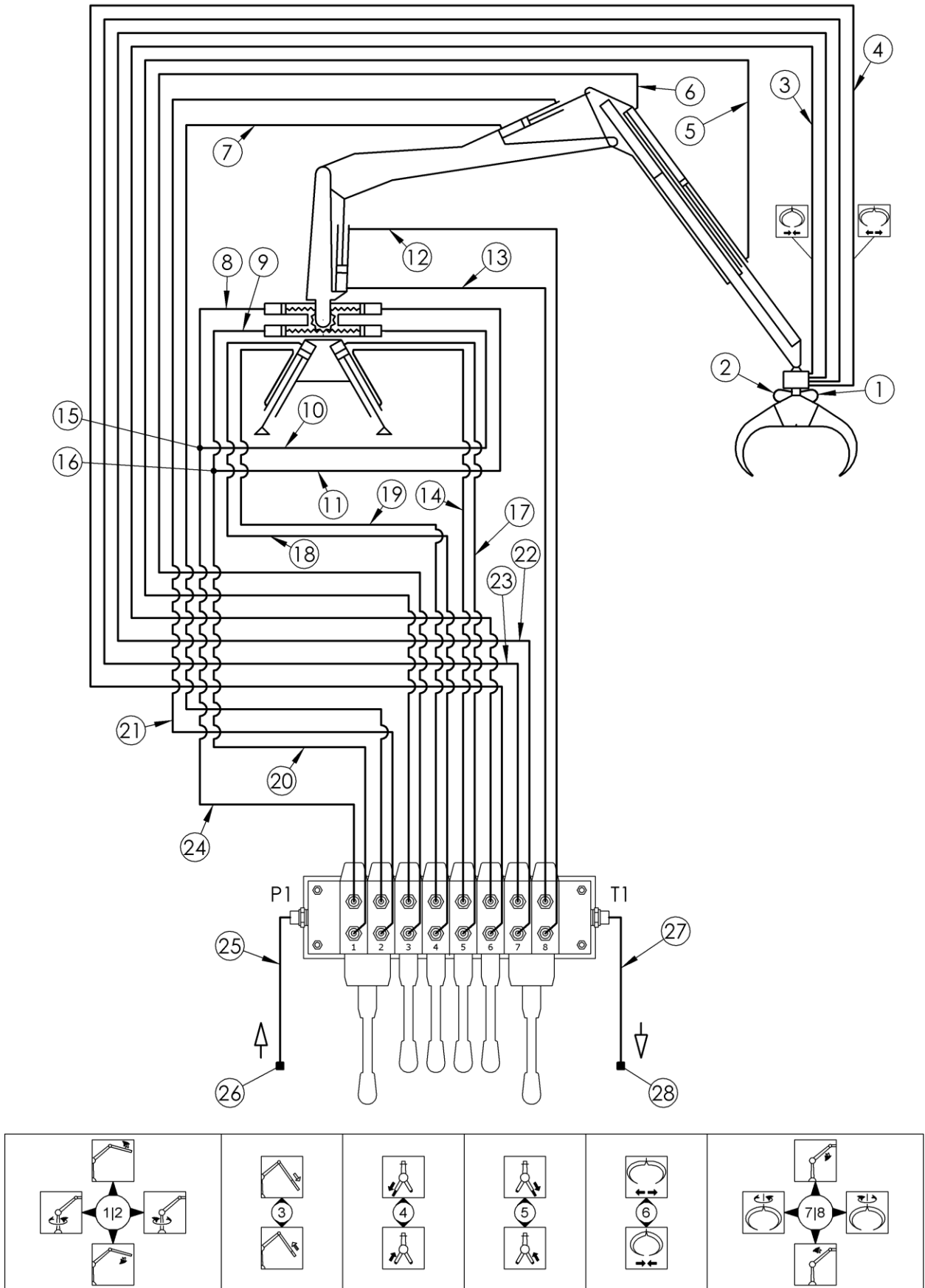

Figure 15. Hydraulic diagram for Nordhydraulic NH 6/8 XY (A3) control valve

6. OPERATING INSTRUCTIONS

6.1 Testing

Ensure that the control valve levers are in the middle position. Switch on the pump and let oil flow through the valve for a while. Lower the support legs.



Ensure that there are no people or obstacles in the operating area. The danger zone is 20 m!

Carefully drive crane movements one by one in the way, that all cylinders reach their extreme positions and repeat this until all movements are smooth.



**Be careful when getting air out of system. If you drive cylinder to its extreme position at full force, the air pressure in the cylinder will damage the seals!
Be extremely careful, when there is air in the cylinders!**

After testing forest crane, inspect connections and repair leaks if any appeared. Check the mounting bolts of the crane and support leg, tighten them if necessary. Check the hydraulic oil level, and fill up if necessary.

6.2 Practice runs



Forest crane should not be operated if temperature is below -25°C. Note that the hydraulic seals, hoses and steel structures may get damaged at low temperature. When starting to work at cold temperature, first let the oil flow freely through the valve for a couple of minutes. The maximum operating temperature for hydraulic oil is +75°C.

Drive through every movement with an unloaded crane, paying attention to the positions in which the crane might hit surrounding obstacles.



Never move the boom to its extreme position at full speed!

Move the control levers smoothly and stoutly, avoiding quick and jerky movements. Learn to use several functions simultaneously. Start at low engine speed to avoid sudden movements. After you have become accustomed to the crane's movements, choose appropriate engine speed so, operations are smooth and efficient, but you still have the movements under control. Loading big and heavy logs from distance, keep load close to the ground. When reaching the trailer, lift it up to load. When unloading do vice versa.

Working on inclined surface, do not operate with the full lifting torque and be extremely careful. Loading uphill note, that turning crane with too much load might cause the oil pressure in slewing device cylinders to reach critical point, where shock valve has to intervene. This could make slewing device uncontrollable and crane might turn back to downhill direction in a way, that it might fall over. In such case lower the load as close to ground as possible, but not too rapidly .



Use the support legs only for purpose to provide additional support for the vehicle! Don't forget to lift the support legs UP before moving to another place!

Support legs are equipped with extra valves, wich will keep them in working position in case feeding hoses of support leg cylinder breakes.



Do not exceed the speed limit when driving! Adjust speed according to the road and weather conditions. Be especially careful on turns! For driving always attach crane by grapple to trailers frame. When driving with load, leave one log sticking out from pile and attach crane by grapple to it. Keep crane boom as low as possible.



Do not use support legs in DOWN position while parking!

When using forest crane in combination with forest trailer, use trailer parking leg (fig.8) and make shure, that crane support legs are not leaning to the ground.

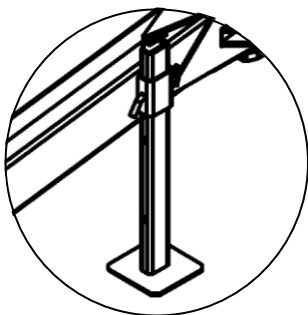

Figure 16. Parking leg of trailer

7. DETACHING FOREST CRANE

Choose sufficiently hard and even level ground for detaching forest crane. Ensure, that no unauthorized persons are around crane during detaching and storing process. When storing control valve, make sure it is out of the reach of children.

- Lower the support legs to support crane properly.
- Fix crane firmly by proper hoist.
- Make sure that crane can not lean or fall over.
- Detach quick couplings and put covers on them.



Always switch the pump off before disconnecting quick couplings!

- Detach crane from the vehicle.

8. STORAGE INSTRUCTIONS

- Clean forest crane and if necessary, repaint any points, where paint has peeled off or gets damaged, this will avoid rust.
- Lubricate forest crane thoroughly (see lubricating instructions).
- Do not leave electric operated and pilot operated valve controls uncovered, water and moist may damage wiring and contacts.
- Release pressure from the cylinders.
- Protect the cylinder piston rods and exposed parts of the control valve with grease.
- Store forest crane in a sheltered area (under the roof), avoid direct contact with the ground.

9. MAINTENANCE

9.1 Maintenance table

OBJECT	ACTION		
	Maintenance interval, working hours		
	8 h or after working shift	40 h or after working week	320 h
1. Crane	Check cylinders and hoses for leakages	Check pins and lockings, tighten mounting bolts	Check the condition of primary structures
2. Slewing device	Grease bearings		Check mounting bolts, tighten if needed. Check gear racks, adjust if needed
3. Booms and ext	Grease slide bearings, cylinder eyelets and joints		Check slide bearings and adjust if needed, change if necessary
4. Cylinders	Grease eyelets		Check hydraulic cylinders
5. Grapple	Grease joints		Check grapple-rotator junction
6. Support legs		Grease joints and cylinder eyelets	

Table 4. Maintenance table

9.2 Adjusting the racks

- Turn column into center position.
- Release the locking nut widely enough, so it will not obstruct tightening (pos. 2 fig. 17).
- Tighten the bolt (pos. 1, fig. 17) against the gear rack with 20-25 Nm (2-2,5 kg*m).
- Tighten the locking nut (pos. 2 fig. 17).
- Repeat same procedure with both bolts.
- Make sure you adjust bolts after every 200 working hours.
- With professional everyday usage, tighten bolt at least once a month.

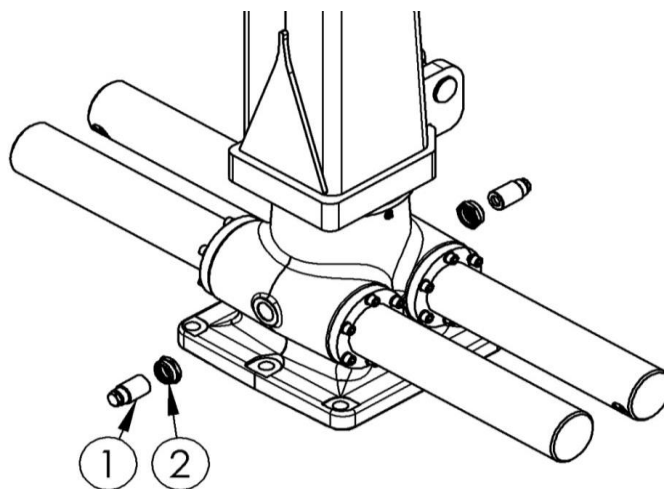

Figure 17. Adjusting racks of slewing device

9.3 Changing oil in slewing device

There is Addinol SAE 80W90, API GL4, GL5 oil in slewing device by manufacturer.

1. Change oil after 960 working hours or once a year.
2. Ensure that the slewing device is in horizontal position, as shown on fig. 17.
3. Release the lock nut (pos. 2, fig. 17).
4. Remove the bolt (pos. 1, fig. 17).
5. Pump the oil out with appropriate pump.
6. Fill up the slewing device with appropriate oil.
7. Tighten the lock nut according to manual's point 9.2 (pos. 2, fig. 17).



Oil should be changed at least once a year. Oil level has to be up to the lower edge of bolt hole (pos. 1)!

During the first oil change open turning house base cover (mounted with 4 bolts) and remove accumulated particles. Then replacing base cover, use oil resistant silicone.

If there is need to change gearrack's polypack gaskets, change always oil as well.

Follow environmental regulations. Drain and collect old oil in to specific container.

9.4 Lubrication

Using the appropriate lubricants like Beacon EP2, Multipurpose GR Moly, Mobilux EP2, Mobil Grease MP Special, Energrease LS-EP2 or similar.

Right lubricants guarantee troublefree operation of the machine.

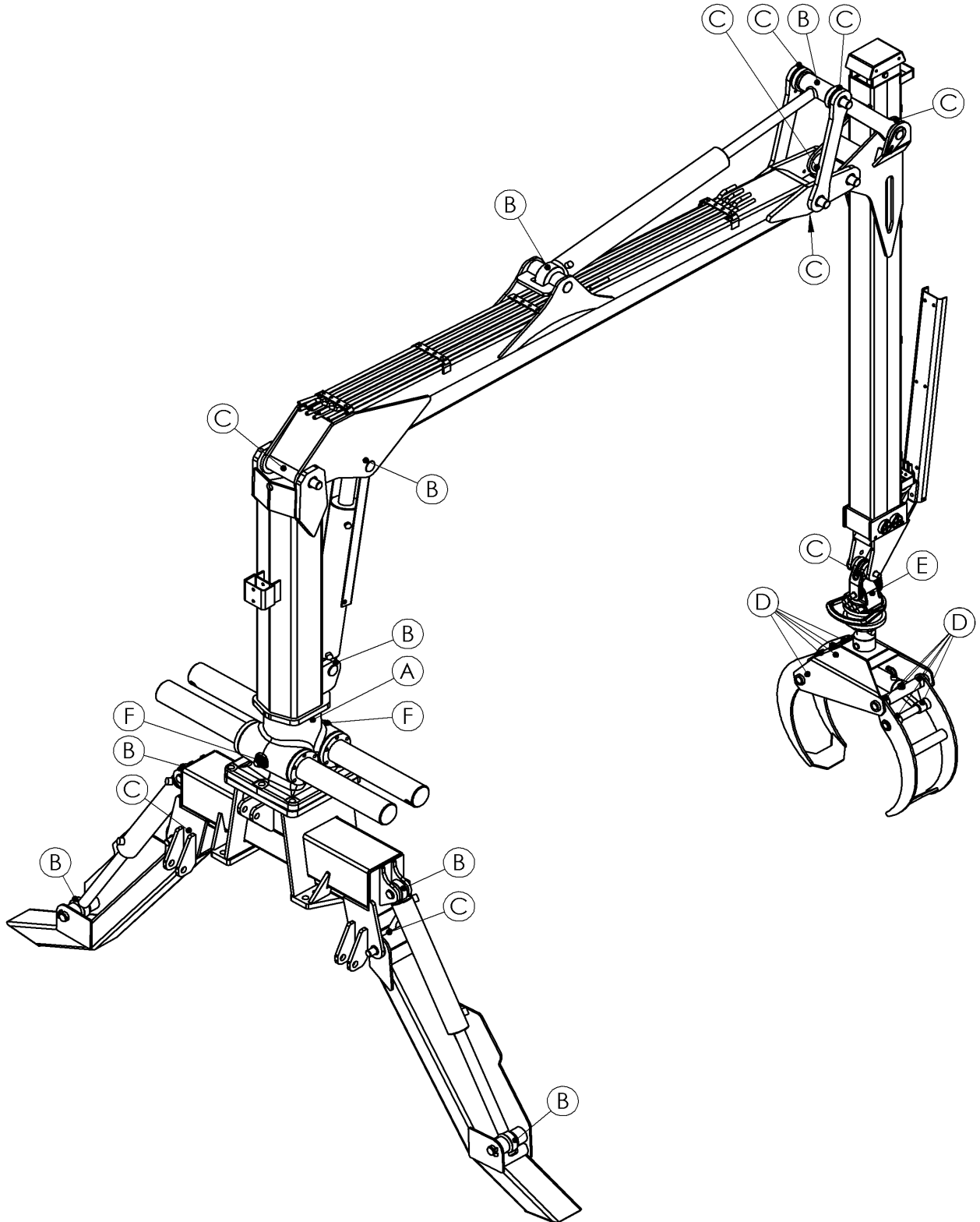

Figure 18. Greasing points of Palms 700

Lubrication point	Qty	Action	Interval, h	Notes
Slewing device				
1. Bearings, A	1	Greasing	8	2% molybdensulfide
2. Slewing device, F	1	Oil	2000	Addinol STOU SAE 80W90
Booms				
3. Joint, C	7	Greasing	8	2% molybdensulfide
4. Cylinder eyelet, B	4	Greasing	8	2% molybdensulfide
Grapple				
5. Joint, D	10	Greasing	8	2% molybdensulfide
Rotator				
7. Joint, E	1		8	2% molybdensulfide
Support legs				
8. Joint, C	2	Greasing	40	2% molybdensulfide
9. Cylinder eyelet, B	4	Greasing	40	2% molybdensulfide

Table 5. Oil and lubricant grade table of Palms 700

9.5 Changing the hydraulic oil

Change hydraulic oil at least once in two years. Forest crane hydraulic system has been filled with Addinol HVLP ISO VG. 32 hydraulic oil at the factory. If the oil temperature does not exceed 75°C in summer, winter oil can be used all year round.

We recommend to use high pressure oil filter with indicator (which shows, when filter element is dirty and needs to be changed).

9.6 Hydraulic oil requirements



- Freezing point must be below -50°C.
- Viscosity must not be lower than 1.5 E°, +50°C for piston pumps and 2.5 E°, + 50°C for gear pumps.
- Hydraulic oil must contain the necessary additives for lubrication, rust protection and defoaming.

10. TROUBLESHOOTING

TROUBLE	POSSIBLE CAUSE	REMEDY
CRANE'S WORKING MOVEMENTS ARE SLOW	PUMP RUNNING TOO SLOWLY	CHECK PUMP ROTATING SPEED
	NOT ENOUGH OIL	ADD OIL (AIR-BLEEDING)
	FAULTY PUMP	CHANGE OR GET THE PUMP FIXED
	LEAKS OR OBSTRUCTIONS IN OIL LINES	INSPECT AND CLEAN OIL LINES
	OIL IS TOO THICK	CHANGE TO A THINNER (PROPER) OIL GRADE
CRANE'S DESCENDING MOVEMENTS ARE SLOW	OBSTRUCTIONS IN THE OIL LINES	CHECK THE LINES AND THE CHOKES
	CLOGGED-UP (RETURN) FILTER	CLEAN OR RENEW FILTER
	OIL TOO THICK	CHANGE TO A THINNER (PROPER) OIL GRADE
CRANE'S MOVEMENTS ARE TOO FAST	ROTATION SPEED TOO HIGH OR PUMP IS TOO POWERFUL	CHOOSE A CORRECT PUMP/ SPEED OF ROTATION
	INCORRECT OPERATION	LEARN TO OPEN THE CONTROL VALVE TO A SUITABLE DEGREE
CRANE'S WORKING MOVEMENTS ARE POWERLESS	NOT ENOUGH OIL	ADD OIL (ALSO AIR BLEEDING)
	FAULTY PUMP	CHANGE OR GET THE PUMP FIXED
	FAULTY OF RELIEF OR SHOCK VALVES OR WRONG ADJUSTMENT	CHANGE THE RELIEF OR SHOCK VALVES OR ADJUST IN RIGHT WAY
	FAULTY CONTROL VALVE	CHANGE OR GET THE VALVE FIXED
	FAULTY CYLINDERS OR SEALS	CHECK THE CYLINDERS AND CHANGE THE SEALS
CRANE'S MOVEMENTS ARE JERKY	AIR IN HYDRAULIC SYSTEM	CHECK OIL LEVEL, BLEED AIR FROM SYSTEM
		CHECK FOR OBSTRUCTIONS OR LEAKS ON THE INLET SIDE
	FAULTY PUMP	INSPECT THE PUMP AND GET IT FIXED
BOOMS DESCEND BY THEMSELVES	FAULTY CONTROL VALVE	REPLACE/FIX THE VALVE
	FAULTY CYLINDERS OR HOSES	FIX THE LEAKAGE POINT, CHECK CYLINDER SEALS
CONTROL VALVE STEMS ARE STICKING	VALVE'S FIXING SCREWS TOO TIGHT	CHECK SCREWS TIGHTENING TORQUE (50 Nm (5 kPm, 37 ftXlb))
	VALVE NOT ON LEVEL MOUNTING BASE	MOUNT THE VALVE ON A LEVEL BASE
	VALVES' TIE BOLTS TOO TIGHT	CHECK SCREWS TIGHTENING TORQUE 27,5 Nm (2,75 kPm, 20 ftXlb)
GRAPPLE'S OPENS BY ITSELF	FAULTY VALVE	FIX THE VALVE
	FAULTY CILINDER OF THE GRAPPLE	FIX OR CHANGE THE CILINDER
	FAULTY ROTATOR	FIX OR CHANGE THE ROTATOR

Table 6. Troubleshooting table

11. SPARE PARTS

11.1 Main parts

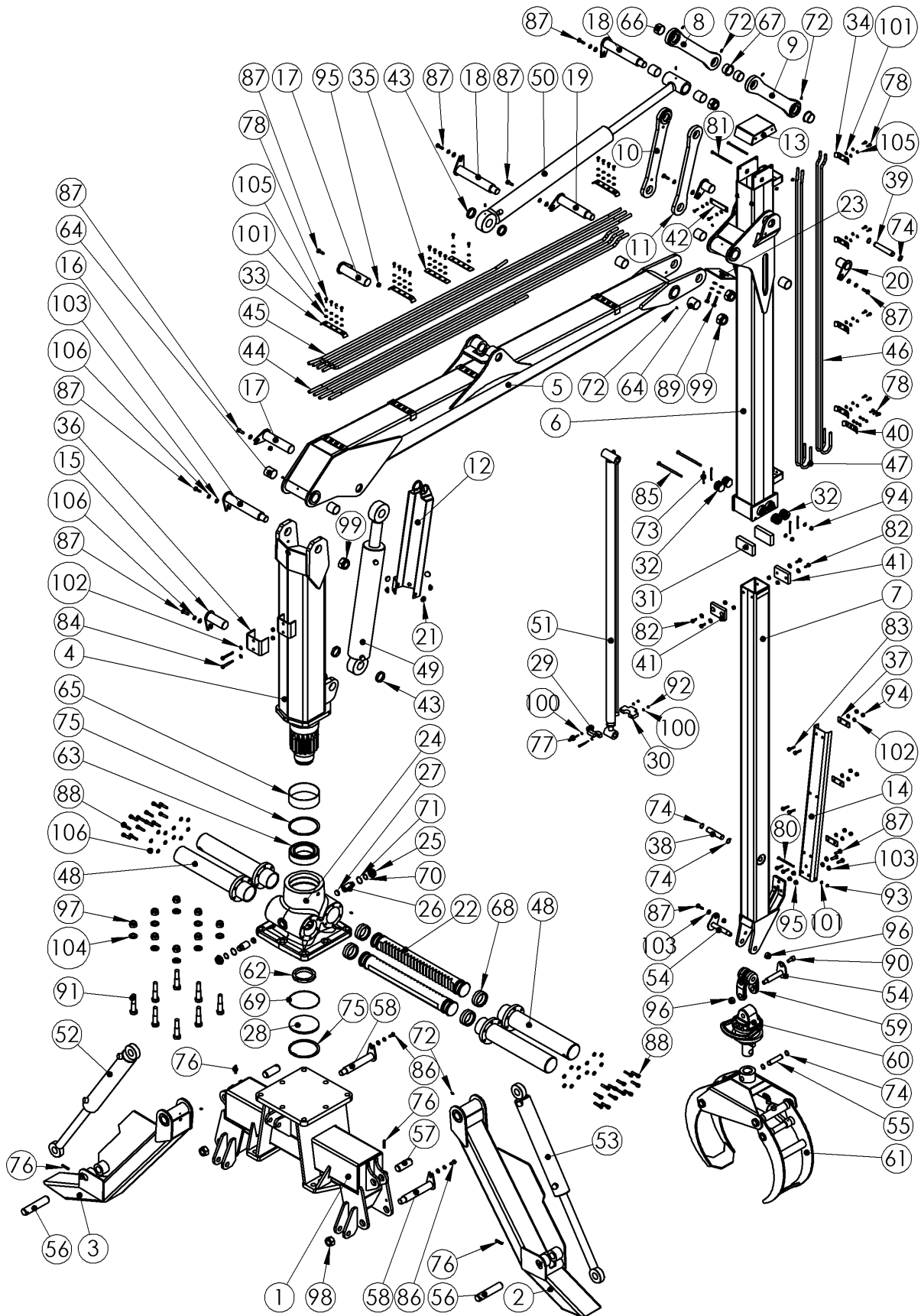

Figure 19. Spare part positions of Palms 700 forest crane

FOREST CRANE PALMS 700

Pos	Code	Part name	Qty
1	70090001	Housing of FD-legs	1
2	70090002	FD-leg outrigger left	1
3	70090003	FD-leg outrigger right	1
4	70090004	Column	1
5	70090005	Main boom	1
6	70090006	Ext boom	1
7	70090007	Telescope	1
8	70090008	Puller 1	1
9	70090009	Puller 2	1
10	70090010	Puller 3	1
11	70090011	Puller 4	1
12	70090012	Cylinder cover	1
13	70090013	Cover of ext. boom hoses	1
14	70090014	Saddle	1
15	70090015	Cylinder shaft on column	1
16	70090016	Shaft on column/main boom joint	1
17	70090017	Cylinder shaft on main boom	2
18	70090018	Shaft of wide angle joint	2
19	70090019	Shaft on main/ext. boom joint	1
20	70090020	Shaft of ext. boom puller	2
21	70090021	Slider of cylinder cover	5
22	70090022	Gear rack	2
23	70090023	Mounting plate of ext. boom hoses	1
24	70090024	Housing of slewing device	1
25	70090025	Locking nut	2
26	70090026	Supportive bolt	2
27	70090027	Supportive slider	2
28	70090028	Cover of slewing device housing	1
29	70090029	Telescope cylinder support 1	1
30	70090030	Telescope cylinder support 2	1
31	70090031	Ext.boom slider	2
32	70090032	Ext.boom threaded slider	4
33	70090033	Tube clamp curved	3
34	70090034	Hose clamp on ext.boom	4
35	70090035	Tube clamp stright	2
36	70090036	Hose clamp on column	1
37	70090037	Clamp of saddle	3

FOREST CRANE PALMS 700

Pos	Code	Part name	Qty
38	70090038	Shaft of telescope cylinder	1
39	70090039	Shaft of telescope cylinder	1
40	70090040	Tube clamp on ext. Boom	1
41	70090041	Slider of telescope	2
42	70090042	Tube clamp on main boom	1
43	70090043	Distance ring	4
44	70090044	Tube 1 on main boom	6
45	70090045	Tube 2 on main boom	2
46	70090046	Tube 1 on ext. boom	2
47	70090047	Tube 2 on ext. boom	2
48	70090048	Hollows 90x450+65	4
49	70090049	Main boom cylinder	1
50	70090050	Ext. boom cylinder	1
51	70090051	Telescope cylinder	1
52	70090052	FD-leg cylinder L	1
53	70090053	FD-leg cylinder R	1
54	70090054	Shaft of hanger	2
55	70090055	Grapple shaft 25x93	1
56	70090056	Shaft	2
57	70090057	Shaft	2
58	70090058	Shaft with heel	2
59	70090059	Hanger	1
60	70090060	Rotator	1
61	70090061	Claw	1
62	70090062	Nut M100x2	1
63	70090063	Spherical roller bearing 23022E	1
64	70090064	Bronze slide bearing 50-45x50	8
65	70090065	Bronze slide bearing 170-165x60	1
66	70090066	Bronze slide bearing 50-45x50 WB800	2
67	70090067	Bronze slide bearing 50-45x50 WL-B800	2
68	70090068	Polupac-gasket DBM 275196	4
69	70090069	ISC O-ring 172-3 NBR	1
70	70090070	ISC O-ring 30-3 NBR	2
71	70090071	ISC O-ring 38-2 NBR	2
72	70090072	Lubrication nipple M6	14
73	70090073	Cotter pin 5x71 DIN 94	4

FOREST CRANE PALMS 700

Pos	Code	Part name	Qty
74	70090074	Locking hoop ø25x1.2 DIN 471	6
75	70090075	Locking hoop ø170x4.0 DIN 472	2
76	70090076	Cotter pin ø10x50 DIN 148	4
77	70090077	Hex head cap bolt M6x70 DIN 931	2
78	70090078	Hex head cap bolt M8x20 DIN 933	29
79	70090079	Hex head cap bolt M8x25 DIN 933	2
80	70090080	Hex head cap bolt M8x120 DIN 931	1
81	70090081	Hex head cap bolt M8x150 DIN 931	2
82	70090082	Hex head cap bolt M10x25 DIN 933	4
83	70090083	Hex head cap bolt M10x40 DIN 933	6
84	70090084	Hex head cap bolt M10x80 DIN 931	2
85	70090085	Hex head cap bolt M10x180 DIN 931	2
86	70090086	Hex head cap bolt M12x25 DIN 933	2
87	70090087	Hex head cap bolt M12x35 DIN 933	13
88	70090088	Flat socket cap bolt M12x45 DIN	24
89	70090089	Hex head cap bolt M12x50 DIN 933	2
90	70090090	Flat socket cap bolt M16x30 DIN	1
91	70090091	Hex head cap bolt M24x110 DIN 931	8
92	70090092	Nylon lock nut M6 DIN 985	2
93	70090092	Nylon lock nut M8 DIN 985	3
94	70090094	Nylon lock nut M10 DIN 985	14
95	70090095	Nylon lock nut M12 DIN 985	6
96	70090096	Nylon lock nut M20 DIN 985	2
97	70090097	Nylon lock nut M24 DIN 985	8
98	70090098	Nylon lock nut M30 DIN 985	2
99	70090099	Nylon lock nut M36 DIN 985	4
100	70090100	Washer M6 DIN 125	4
101	70090101	Washer M8 DIN 125	32
102	70090102	Washer M10 DIN 125	10
103	70090103	Washer M12 DIN 125	22
104	70090104	Washer M24 DIN 125	8
105	70090105	Spring washer M8 DIN 127 B	31
106	70090106	Spring washer M12 DIN 127 B	35

Table 7. Spare part list of Palms 700 forest crane

12. WARRANTY

The machine shall not be taken into use before the operating manual is thoroughly read and understood.

Duration of warranty:

- Parts manufactured by Palmse Mehaanikakoda LLC, warranty is three years.
- Hydraulic components, sliding bearings, cylinders, rotators, pumps, valve blocks and all other parts and equipment not manufactured by Palmse Mehaanikakoda LLC, manufacturer warranty applies.

The warranty does not apply:

- to any faults or defects arising from normal wear, negligence or improper operation.
- to faulty installation or incorrect or inadequate maintenance.
- if during maintenance or repairs were not original or same quality level as originals spare parts used.

The warranty is invalidated:

- if any repairs or constructional changes to the warranted products have been made by others than the manufacturer or a service shop authorized by the manufacturer or if the equipment has been altered without co-ordination with manufacturer.
- if the settings of the pressure relief valves of the loader's directional control valves have been changed without co-ordination with manufacturer.

Palmse Mehaanikakoda LLC will be not responsible for any damages caused by the improperly handled machine.

The manufacturer will not assume any liability for any economical losses or for any consequential damage to persons or property, which may incur during product's usage or failure.

Product warranty is **NOT VALID** in case of user's incompetence and/or irrespective handling of the equipment. Warranty does not cover transportation cost, repairing labor or loss of profit due to normal abrasion or product failure.

Manufacturer:

Palmse Mehaanikakoda LLC

Võsupere

Lääne-Virumaa

45 202 Estonia

Tel +372 32 55 375

Fax +372 32 55 378

info@palms.eu

www.palms.eu