

NOKKA 

Grapple Loaders & Forestry Trailers



FOREST PRO 1042 & 106HD

ATV-SERIES

FORESTRY TRAILERS
& GRAPPLE LOADERS

Adept Machines



- *Quick to couple and uncouple*
- *Self-powered and fully integrated hydraulic aggregate*
- *Standardly equipped with hydraulic four-wheel drive and longitudinally extendable frame*



Nokka ATV-series: Forest Pro 1042 & 106HD



Additional equipment:

Gravel bucket - volume 100 litres

Radio controlled hydraulic winch - 5mm / 25 m, pulling capacity approx. 500 kg

Tipping body (on top of the basic frame)

Energy grapple 105E - weight 52 kg, max log diameter 12 cm

Honda engine (as an alternative to the standard engine)

Adept Machines

- Hydraulically controlled longitudinal frame extension, adjustable to fit the length of wood being loaded
- Self-contained hydraulic aggregate (motor, container, pump)
- Hydraulic four-wheel drive, also powering conveyor rollers that add to pulling capacity
- Quick coupling and uncoupling for ATV tow bars
- Flange mounted loader
- Hydraulic telescopic support legs
- Unlimited grapple rotator
- Hydraulic boom extension in loader
- Wide angle joint in loader

HK 1042

Weight with timber grapple, kg	285
Gross lifting momentum, kNm	10
Net lifting momentum, kNm	7,6
Swing momentum, kNm (pressure 182 bar)	2,3
Boom turning angle, 220°	220 °
Maximum reach, m 4.2	4,2
Mounting system	flange, oil/grease, 2 cylinder
Lifting capacity at 2 m reach, kg (without grapple and rotator (+60 kg))	400
Lifting capacity at max.reach, kg (without grapple and rotator (+60 kg))	165
Combined weight without valve system, kg (valve +37 kg)	630
Grapple, m ³	0,08
Max. opening of grapple, cm	75

MV 106HD ATV

Weight without loader, kg	345
Load capacity, speed 0-20 km/h, kg	1 000
speed 20-60 km/h, kg	290
Total weight, kg	1 630
Width, cm approx.	n. 130
Length, cm	285-430
Height with loader, cm	~185 cm
Length of load space, cm	187+100
Loading area, m ²	0,65
Track width, cm	104
Ground clearance, cm	33
Motor, hp	5,4
Pump output, l/min	9
ax. working pressure, bar	182
Hydraulic oil tank, l	9,3
Tyres	22*11.00-8

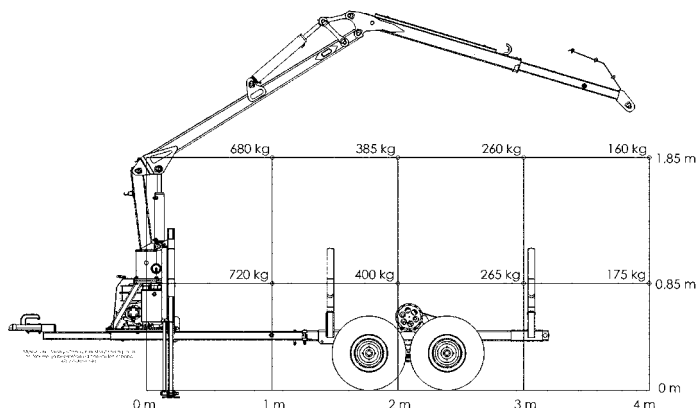

Nokka Oy

Nokka Oy
 40950 Muurame, Finland
 Tel. +358 44 762 4500
 Fax +358 14 310 0205
 Email: nokka@nokka.fi
www.nokka.fi