

# OPERATION, MAINTENANCE AND SPARE PARTS MANUAL

---

## CHIPPER AND HYDRAULIC FEEDER FEED CONVEYOR HFC **FARMI 381 HFC / HF Expert**

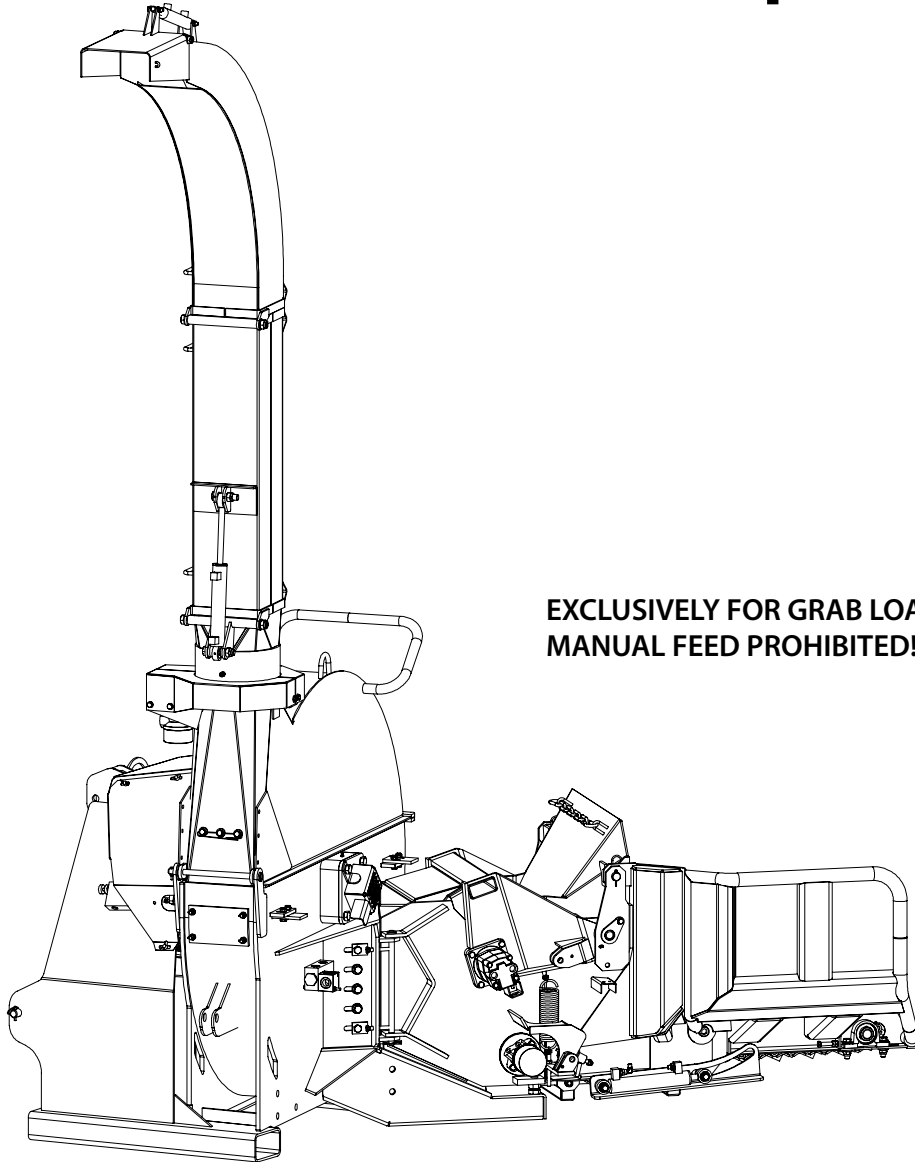

**EXCLUSIVELY FOR GRAB LOADER FEED!  
MANUAL FEED PROHIBITED!**

**READ THIS OPERATION AND MAINTENANCE MANUAL CAREFULLY  
BEFORE USING THE MACHINE**

---

**FARMI**<sup>®</sup>  
FOREST

Farmi Forest Corporation  
Ahmolantie 6  
FIN-74510 Iisalmi, Finland  
Tel. +358 (0)17 83 241  
Fax. +358 (0)17 8324 372  
[www.farmiforest.fi](http://www.farmiforest.fi)

# FARMI 381 HFC / HF

---

## PRODUCT WARRANTY

Farmi provides a 12-months warranty on all Farmi products.

Register on our home page ([www.farmiforest.fi](http://www.farmiforest.fi)) under FeedBack ("Product Registration" form) within 30 days after the receipt of the product to get full product warranty and additional information on your product. If it is not possible for you to register via internet, please register as follows: Complete the registration form on the last pages of this manual and return it to us within 30 days after the receipt of the product.

## WARNINGSYMBOLS IN THIS MANUAL



- **imminent danger which could cause serious personal injury or death**



- **danger which could cause personal injury**



- **conditions or misuse that could damage equipment or machinery**
- **reminders, such as for performing checks or carrying out maintenance or repair procedures**

## INTRODUCTION

This manual includes the information and maintenance instructions required for operating the machine in the optimal manner.

Although you have experience in using this kind of machinery, read the operation and maintenance instructions carefully since they include information enabling efficient and safe operation. Regular maintenance is the best way to guarantee the efficient and economical performance of the machine.



**Each and every operator must read, understand, and follow all safety instructions and procedures.**

## CUSTOMER FEEDBACK

We are happy to receive your opinions and suggestions for improvements by mail, fax or e-mail. All implemented suggestions for improvements will be rewarded.

# FARMI 381 HFC / HF

---



## EC DECLARATION OF CONFORMITY

**Manufacturer:**

Farmi Forest Corporation  
Ahmolantie 6, FIN-74510 IISALMI, Finland

**Person authorized to compile the technical documentation:**

Name: Matti Berg  
Address: Ahmolantie 6, FIN-74510 IISALMI, Finland

**Commercial name:**

Farmi

---

**Machine denomination:**

Farmi wood chipper with Farmi feed hopper

---

**Machine type:**

FARMI 381 HFC / HF

---

**Machine series number:**

---

Herewith, we declare that the machine brought into circulation conforms with the pertinent requirements of the Machinery Directive 2006/42/EC and the EMC Directive (directive relating to electromagnetic compatibility) 2004/108/EC. The following harmonized standards have been applied for the conceptual design of the machine:

SFS EN ISO 12100

---

The following additional standards and specifications have been applied for the conceptual design of the machine:

SFS ISO 730-1, SFS ISO 2332

---

Iisalmi  
(Place)

18.10.2013  
(date)

---

Jani Kortelainen

# FARMI 381 HFC / HF

## TABLE OF CONTENTS

PRODUCT WARRANTY	2
GENERAL SAFETY INSTRUCTIONS	5
GENERAL SAFETY INSTRUCTIONS FOR THE CHIPPER	8
STICKERS AND PLATES	9
TECHNICAL INFORMATION	12
MOUNTING	15
OPERATION	17
CONTROL EQUIPMENT	17
STARTING UP THE CHIPPER	18
STARTING THE TRACTOR PTO	18
NO STRESS SYSTEM	19
CHIPPING	20
STOPPING THE CHIPPER VIA THE TRACTOR DRIVE	20
CHIPPER TRANSPORTATION	21
STORAGE	21
MAINTENANCE	22
GENERAL MAINTENANCE INSTRUCTIONS	22
MAINTENANCE	23
TENSION OF THE TIMING BELT	25
TENSION OF THE FEED UNIT	25
LUBRICANT TABLE	25
MAINTENANCE	26
WIPER KIT	29
CHIP LENGTH ADJUSTMENT	30
SPLINED SHAFT REPLACEMENT	31
CHIPPER	32
KNIFE, ROTOR AND BEARING UNIT	36
HYDRAULIC UNIT HD381	38
DISCHARGE PIPE, COMPLETE from serialnumber 3800100	40
ACTUATOR FOR DISCHARGE CHUTE ROTATION, COMPLETE	42
TWIG CRUSHER, COMPLETE	44
HYDRAULIC FEEDER HF381	46
FEED CHUTE HF380	48
FEED CONVEYOR FC381	50
HYDRAULICS	52
HOSE SERIES: DIRECTIONAL CONTROL VALVE FROM ABOVE	56
HOSE SERIES: PUMP HOSES	58
HOSE SERIES: FRONT HOSES	60
HYDRAULICS CIRCUIT DIAGRAM	62
PRODUCT REGISTRATION FORM	66

When ordering spare parts, please indicate the machine's type from the machine plate, spare part's order number, description and quantity required. Example. CH381HF, 43800450, knife, 4 pc

# FARMI 381 HFC / HF

## GENERAL SAFETY INSTRUCTIONS

These safety instructions are meant for the owners of FARMI equipment, as well as those who operate, service or repair it.

The instructions help with:

- using the machine safely, appropriately and effectively.
- identifying, avoiding and preventing potentially dangerous situations.

The manufacturer supplies an instruction manual, which must always be available at the place of operation of the machine. Each user must read the safety, maintenance and operating instructions before operating the machine, and comply with these instructions at all times.



**Ensure that every operator of the machine is familiar with the content of the instruction manual and situation-specific safety instructions, and has been suitably trained before operating the machine.**

The machine complies with technical requirements and applicable safety regulations. However, incorrect use, maintenance or repair of the machine may cause risks.

In addition to the instruction manual, remember to comply with regulations of the local occupational health and safety authorities, and with your country's laws and decrees.

**The manufacturer is not liable for damages caused by:**

- incorrect, negligent or inappropriate use of the product.
- non-original spare parts.
- normal wear and tear.
- misuse caused by an untrained person's improper actions.
- alterations made without the manufacturer's permission.



**Written authorization must be requested from the manufacturer for any alterations to the machine.**

## STARTING

- Familiarize yourself thoroughly with the use, operation and controls of the machine and its equipment before starting.
- Familiarize yourself with the capacities and limitations of the machine and its equipment.
- Do not use the machine unless you are completely familiar with its operation.
- Be aware of the machine's danger zones.
- During operation, prevent bystanders from entering the danger zone.
- Ensure that each operator has the necessary safety equipment, such as a helmet, safety goggles, work safety boots and suitable protective clothing.
- Never wear loose clothing around moving parts. Protect long hair!
- Ensure that work is carried out according to the stipulations of applicable occupational health and safety legislation.
- Before starting up or using the machine, ensure that it cannot cause a risk to other people or property.
- Perform a safety check on the machine before every use. If you observe any faults or deficiencies, repair the machine immediately.
- Before operating the machine, ensure that there are no foreign articles in it.
- Place the machine on a hard, level surface for operation. In the winter avoid working in slippery areas.
- Before mounting and using the machine, check the PTO drive shaft for correct condition and attachment.
- Never use a faulty or deficient machine.

# FARMI 381 HFC / HF

## TRANSPORT

- Before driving with the machine, ensure the safe mounting of the machine. Make sure that the journals are seating correctly and that the pins are tight. Check the tension of the lower link stabilizers.
- Before driving with the machine, make sure that the required lamps and reflectors as well as the slow moving vehicle sign are attached correctly. Moreover, the lamps should be checked for correct functioning.
- Before driving with the attached machine, make sure that the hydraulic unit of the machine is depressurized (unless otherwise instructed in the operating instructions).
- When driving on public roads, always observe the valid traffic regulations. The travel speed must be adapted to the specific conditions.
- When driving, please take into consideration the additional mass resulting from the machine's weight. It may affect the reactions, the steerability and the braking function of the tractor.
- Please note that the machine rear sways when turning.
- Pay attention to the machine's height near bridges or other height restricting objects.
- When backing off, the machine may obstruct the rear view. Exercise extreme caution. If necessary, ask a flagman to help you; he can indicate the required distances.
- It is prohibited for other people to ride on the machine.

- If any faults arise that may jeopardize occupational safety, turn off the machine.
- During operation, the machine's operator is responsible for safety in the whole work area. Work may not be carried out in the presence of any factors that jeopardize occupational safety.
- Exercise extreme caution when hitching / unhitching the machine from a tractor/trailer.



**The machine's operator must have constant, unobstructed visibility of the work area. If this is not possible, the operator must work with an assistant.**

- Look out for moving parts when the machine is in operation.
- Secure the machine against unauthorized and accidental operation (e.g. moving when parked) whenever it is left unattended.
- Never leave the machine running unattended.
- Avoid causing fast, stroke-like loading.
- Never exceed the given operating values.
- All safety and warning signs on and in the machine must be legible and intact.
- The machine may not be operated by persons who are unwell or under the influence of drugs or alcohol.

## OPERATION



**Many occupational accidents take place in abnormal circumstances. Therefore it is important to take into account all the possible circumstances that may arise during operation of the machine.**

- Depending on the machine's type, it will have diverse safety devices and protectors. These are meant to protect the machine and its operator, and they must never be removed or altered. Never start up or use the machine without all the safety devices and protectors in place. Also check the universal joint's safety equipment and joints.
- Never insert any body part into the machine with the engine running.
- The machine may only be serviced and repaired by professionals.
- Electrical and hydraulic faults may only be repaired by authorized professionals.
- In cases requiring welding, contact the manufacturer.
- Turn off the tractor engine and disconnect the universal joint before beginning service or maintenance actions.
- Before any maintenance work, turn the main power switch of the tractor to OFF.
- Ensure that there is no pressure in the hydraulic system.
- Take out the key from the tractor's ignition for the duration of the servicing or maintenance. Check that the power is off from the machine you are working on.
- When servicing the machine, place it on a level surface and ensure that it cannot be moved.

# FARMI 381 HFC / HF

- Observe the service intervals and annual safety inspections.
- All spare parts and equipment must fulfill the manufacturer's requirements. This can be guaranteed by using original parts.
- Put all safety devices back into place immediately once servicing or maintenance is complete.



**When lifting the machine, check that the lifting/hoisting equipment is in perfect working order. Check the weight of the machine before lifting it. Choose lifting trajectories so that they do not cause any danger.**

Many countries have specific legislation on lifting, hoisting cables and hoists. Always comply with local safety regulations.

## OILS AND LUBRICATION

- Always use the oil types recommended by the manufacturer. Other types of oil may cause faults or improper operation of the equipment, which could lead to serious damage to people or property.
  - Never mix different liquids or oils.
  - Always follow the manufacturer's lubrication instructions.
  - Use control equipment carefully until the hydraulic oil has had time to reach its operating temperature.
1. Work on hydraulic equipment may only be carried out by professional hydraulic engineers.
  2. Be cautious when using the equipment in cold conditions.
  3. Check the machine for leaks. Do not use the machine if there is a leak from any system. Check all hydraulic hoses – particularly those which are bent during use – and replace any that are in poor condition or have leaks. Ensure that all joints are tight and that the lines are not damaged. Check that all protective caps and filler caps are closed properly. Check the hose sheathing for damage.
  4. Check that all hose connectors, lengths and qualities comply with applicable requirements. When replacing or repairing hoses, use original parts or hoses and connectors recommended by the manufacturer. Check particularly that the pressure classes of the hoses and connectors are suitable to the operating pressure levels.
  5. Check that all safety devices such as pressure relief valves, etc., are in place and work properly. Familiarize yourself with their use. Safety systems may never be bypassed.
  6. Check the main hydraulic parts daily, and always after a fault. Replace any damaged parts immediately.
  7. If a component is damaged, clean it before repairing it. Do not use solvents when cleaning parts.
  8. Do not attempt to carry out repairs that you are not fully familiar with.
  9. Never carry out repairs of the hydraulic circuit when the system is pressurized. When pressurized, the oil spray can penetrate the skin and cause mortal danger.
  10. Never work below a device or component that is only being held up by hydraulics. Use separate supports when carrying out maintenance or repairs. Do not disconnect cylinders or their valves until the machine is well supported.
  11. Most hydraulic oils do not evaporate easily. Risk factors include hot oil, spills and oil mist (pressurized).
  12. If oil gets into your eyes, rinse with plenty of water and contact a doctor.
  13. Avoid prolonged or repeated contact with your skin.
  14. If sprays or contact with the skin cannot be avoided, use protective gloves, goggles and clothing as necessary. Do not use oily clothing.
  15. Avoid discharging hydraulic oil into the environment, as it can pollute waterways and the groundwater. If biodegradable oil is to be used, please contact the manufacturer beforehand and have the suitability of your equipment for the operation with biodegradable oil confirmed by him before such oil is used.
  16. Store the oil in sealed containers provided by the manufacturer. Try to transfer the oil directly from its container into the tank.
  17. If the oil must be passed through other containers, ensure that they are completely clean. Caps, funnels, sieves and filling holes must also be clean.
  18. Never store oil outdoors, as water could condense in it.
  19. Always dispose of oil in a suitable container, never into the environment!

## GENERAL SAFETY INSTRUCTIONS FOR THE CHIPPER



- Please make sure any machine operator has the required personal protective equipment: safety helmet, protective goggles, cut resistant safety boots and required protective clothing.
- The chipper must not be used without being mounted to a tractor. It is prohibited to mount the chipper to another power source.
- It is not permitted to operate the chipper without feed unit or feed hopper.
- It is prohibited to manually load the material to be cut into a feed unit designed for grab loader feed.
- Indoor operation of the chipper is prohibited.
- Always keep a safe distance to the discharge position of the chips.
- Detach the chipper from the tractor before performing any maintenance or repair works. Caution! As a sole exception, adjust the speed of the feed rollers of the hydraulic feed with the machine running. For further instructions, please see the instruction manual of the feed unit concerned.
- Do not remove, lock, disable or modify in any other way the stop lever of the feed unit.
- The feed hopper or the feed unit must not be mounted at a higher or lower position as this would impede the stop lever function.



# FARMI 381 HFC / HF

## STICKERS AND PLATES

The following plates and labels must be correctly attached to the chipper.  
Missing plates / labels must be replaced immediately.

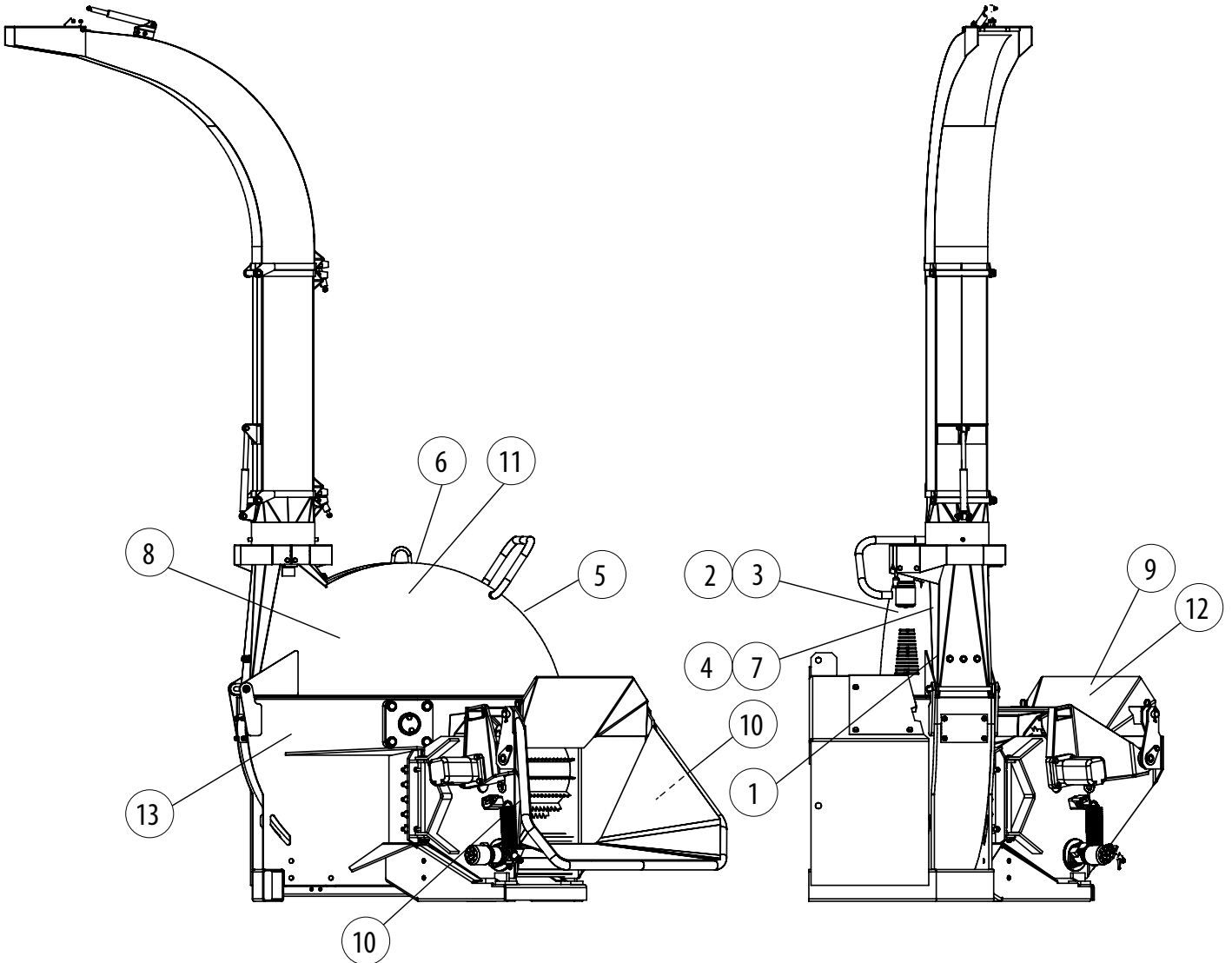

<b>Farmi Forest Corporation</b>		<b>CE</b>	43806940
Ahmolantie 6 FIN-74510 IISALMI FINLAND			
TYPE	WOOD CHIPPER		
MODEL	FARMI 381HF/HFC		
SERIAL NO.			
YEAR OF MANUFACTURE	20		
POWER NEEDED	110-150 kW		
WEIGHT	1970/2300 kg		
MAX. HYDR. PRESSURE	200 bar		
OIL FLOW NEEDED	45 l/min		

Number 1. Machine plate CH381HF / HFC (43806940)

# FARMI 381 HFC / HF



## 2. CAUTION!

Please read the operating instructions of the machine meticulously before you operate, maintain or repair the machine. During machine operation, please observe the operating and safety instructions. (40147020)

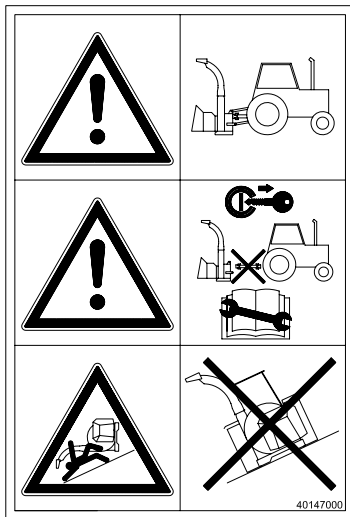

## 3. (40147000)

### CAUTION!

Before operation, mount the chipper to the 3-point hitch of the tractor.

### CAUTION!

Before maintenance and repair, please turn off the tractor and disconnect the PTO drive shaft.

### CAUTION!

Before detaching the chipper from the tractor, it must be placed on a level surface..



## 4. Wear personal protective equipment. (40142080)

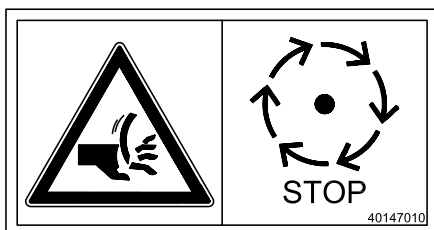

## 5. Cutting hazard! (40147010)

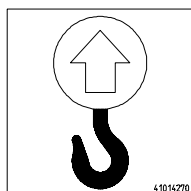

## 6. Lifting point sticker (41014270)

# FARMI 381 HFC / HF

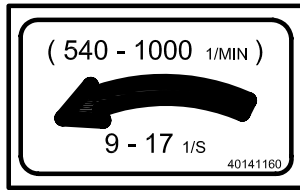

7. *SPEED sticker (40141160)*  
*Recommended speed range.*  
*The rated speed must not be exceeded.*



8. *Farmi Forest sticker (40146900)*

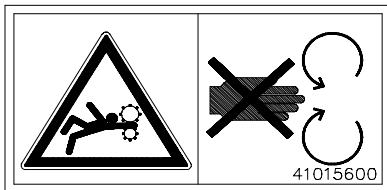

9. *Crushing hazard sticker (41015600)*  
*Always keep a safe distance to rotating parts.*

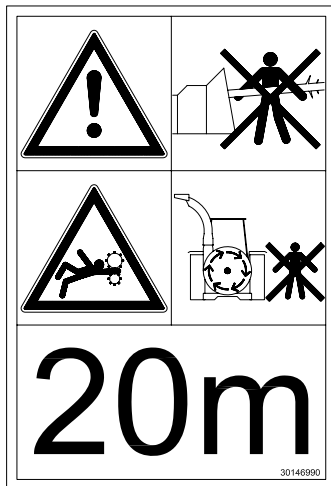

10. (30146990) 2 pcs

**CAUTION!**  
*Manual feed prohibited.*

**CAUTION!**  
*Crushing hazard! Always keep a safe distance to rotating parts.*

**CAUTION!**  
*Safe distance 20 meters.*



11. *Operation from the driver seat in the tractor's safety cab. (40147050)*

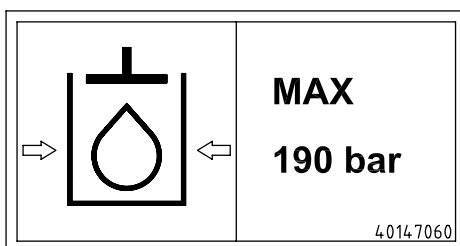

12. *Max. hydraulic pressure 190 bar. (40147060)*

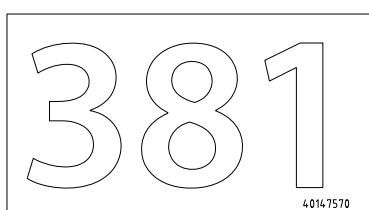

13. *Type sticker (40147570)*

# FARMI 381 HFC / HF

## TECHNICAL INFORMATION

### INTRODUCTION

The FARMI 381 is a 4-knived chipper designed for grapple loader feeding of up to 380 mm diameter stems. The chip size can be adjusted to suit its various end uses, such as biofuel, industrial raw material, soil improvement or dry litter.

The HF381 hydraulic feed chute facilitates processing of difficult to feed materials. The feed chute comes standard equipped with No Stress revolution control, which shuts down the feed when the output Rpm drops too low. The benefits of the No Stress mechanism are:

- tractors of lower power rating can be used
- more homogenous chip quality
- higher chip yield.

The FARMI 381 HF chipper has its own hydraulic unit.

## MAIN COMPONENTS

1. Upper chamber
2. Lower chamber
3. Cutting disk
4. Knife
5. Vertical anvil
6. Horizontal anvil
7. Breaker
8. Discharge pipe
9. Feed unit frame
10. Feed hopper
11. Roller swing
12. Wiper
13. Conveyor feeder

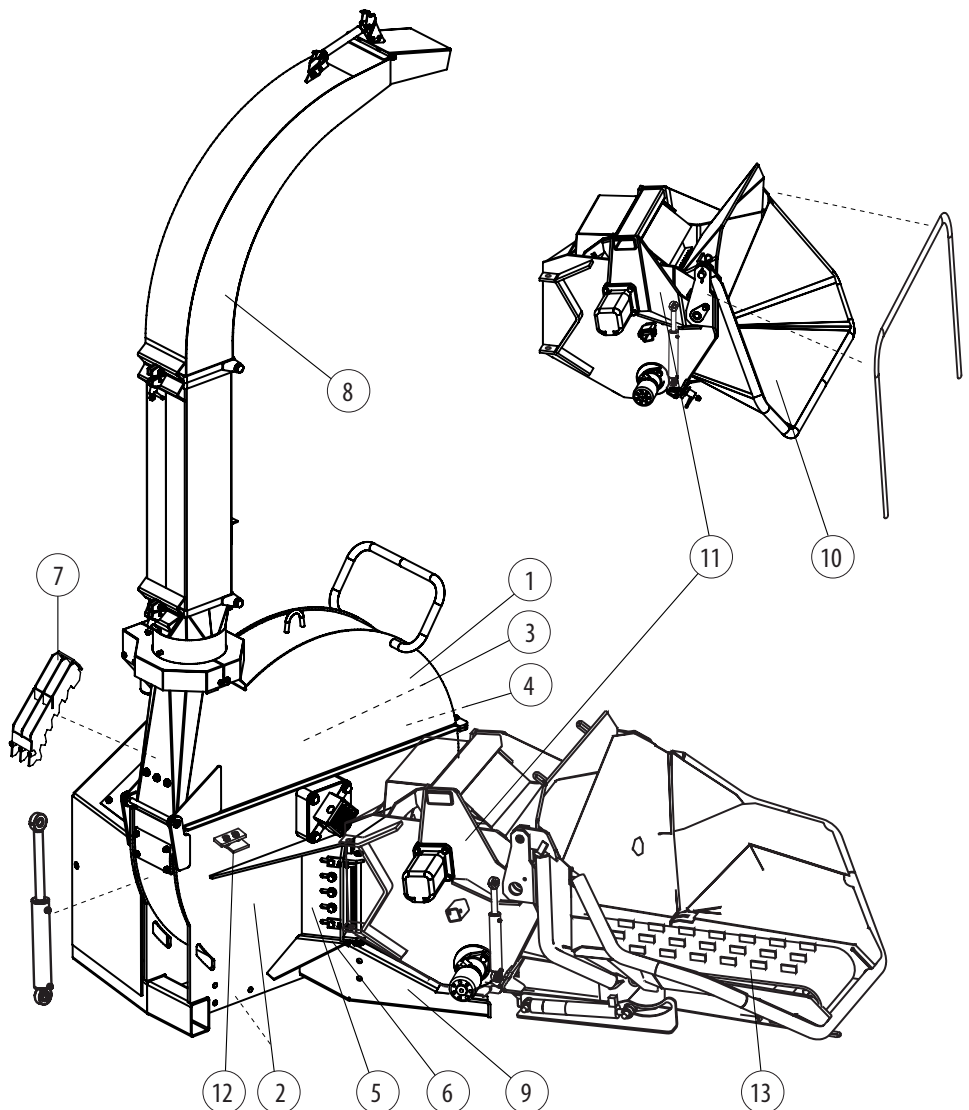

# FARMI 381 HFC / HF

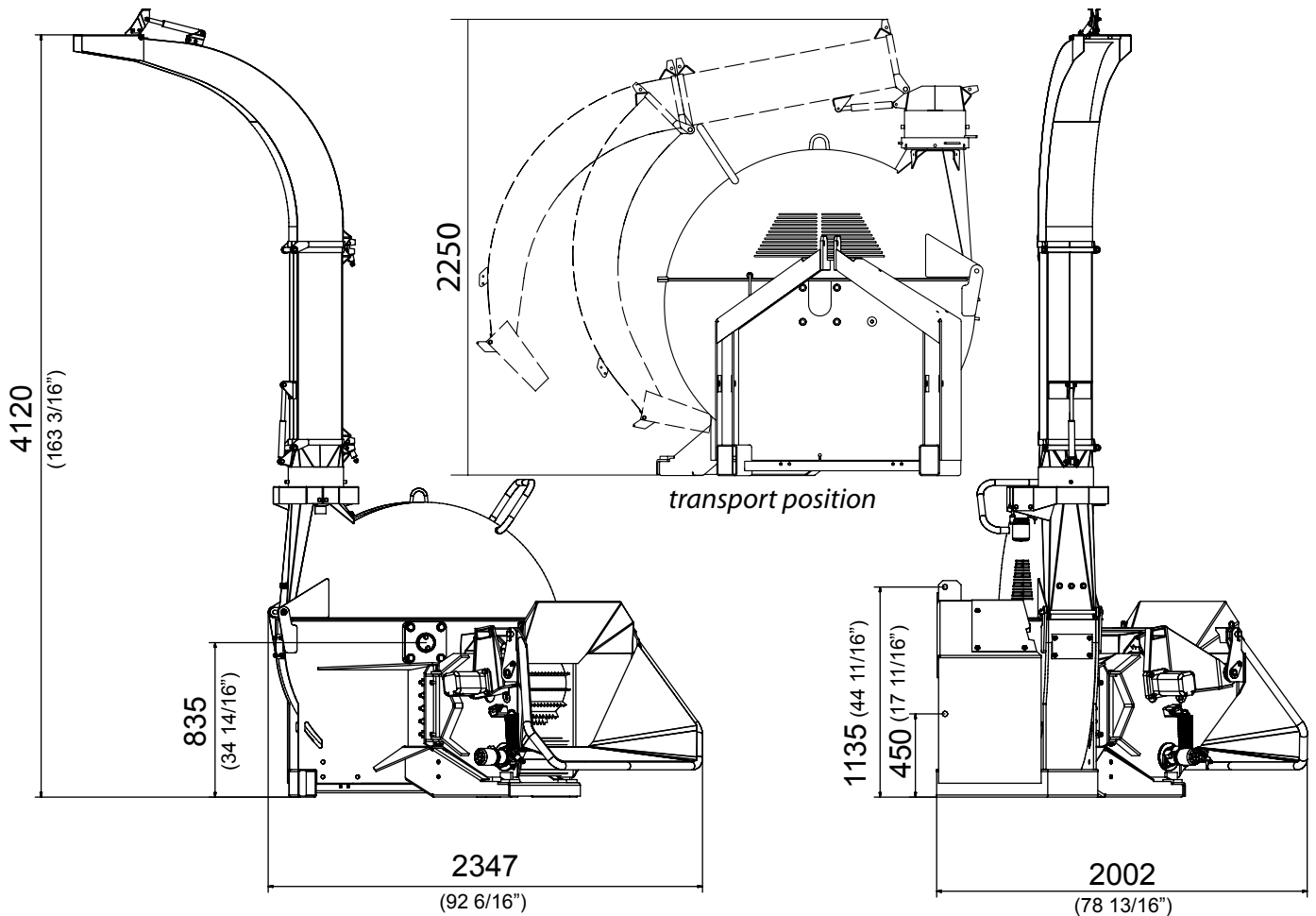

TECHNICAL INFORMATION	FARMI 381 HFC
Type	Double disc chipper
Output, m <sup>3</sup> /h	30-70
Max. stem diameter, mm	380
Feed opening, mm	380 x 420
Chip length, mm / 1000 rpm	10 - 20
Chip length, mm / 540 rpm	20 - 30
Power demand, kW	125-180
Operating rpm	min 540 - max 1000
Number of knives	4
Disc drive	direct, splined shaft 1 3/4", 6 splines
Power source	tractor PTO
Assembly	3-point hitch
Chipper weight, kg	1970
Disc ø, mm	1460
Disc weight, kg	600
2-roller hydraulic feed	standard
Discharge pipe	300° rotating
Discharge control	hydraulic
Operating pressure	190 bar
No Stress rpm guard	standard
Discharge height, m	4,1
Feed control	Radio remote control / display panel / foot pedal
Twig breaker	standard
Hydraulic unit HD38	45 l / 210 bar

# FARMI 381 HFC / HF

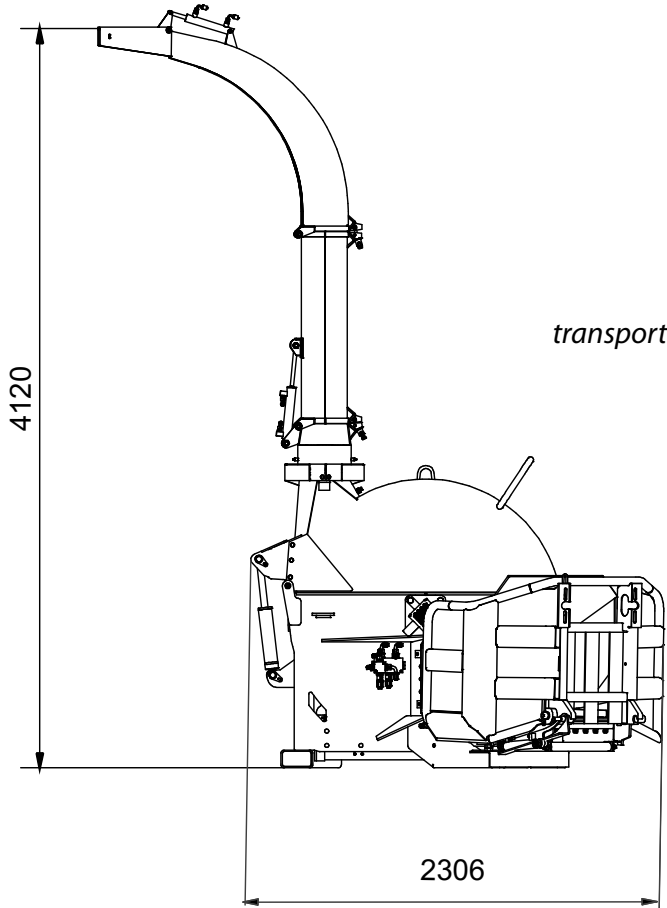
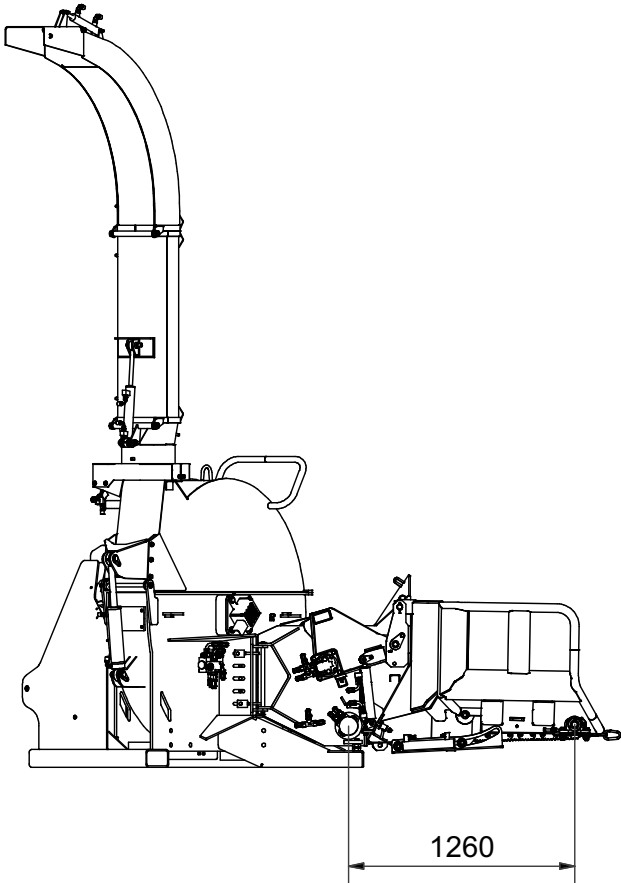
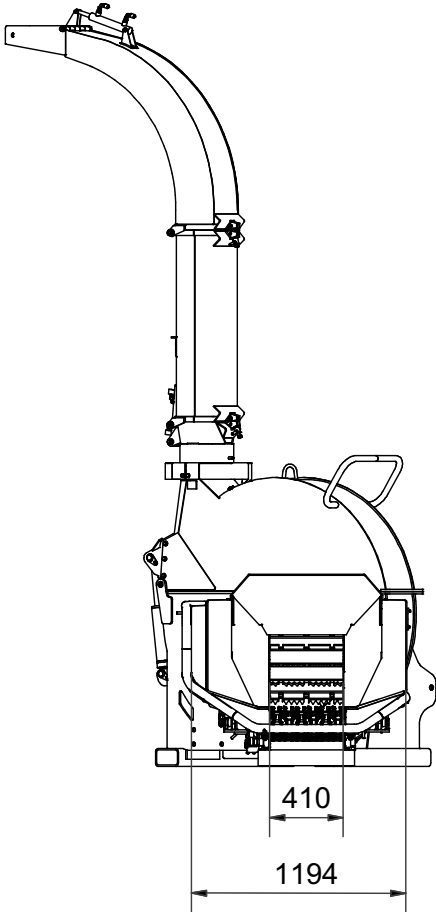

*transport position*

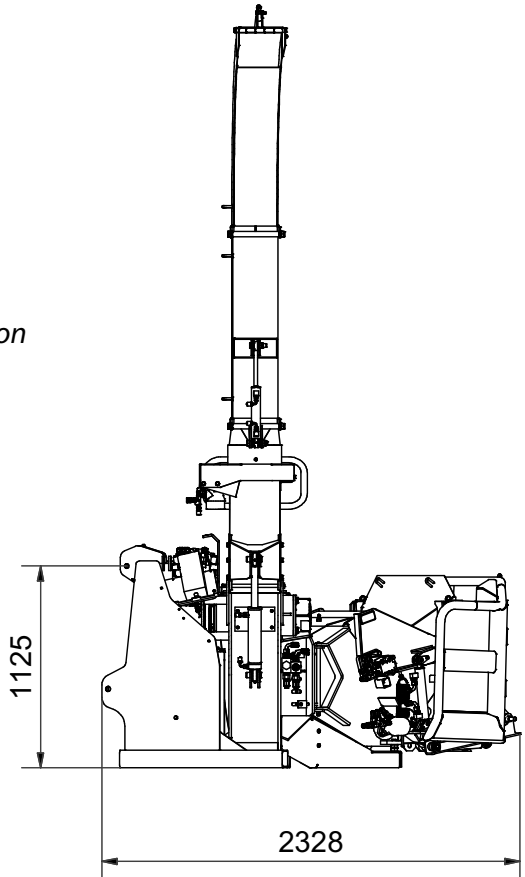

# FARMI 381 HFC / HF

## MOUNTING

### LIFTING



The lifting points are marked on each machine with hook symbols.

Only use appropriate lifting equipment of sufficient lifting capacity to lift the equipment.

Lifting belts, cables and chains used for lifting must be checked regularly.

The weight of the load to be lifted must be known. Never exceed the lifting capacity limit specified by the lifting device manufacturer.

Avoid lifting equipment over areas where people may be present.

## MOUNTING

- Attach the chipper to the tractor's 3-point hitch.
- When handling the chipper, ensure that it is coupled to the 3-point hitch.
- Check that the power take-off (PTO) drive shaft is the correct length. For details on shortening the PTO shaft see the "Power Take-Off Shaft" section.
- Check that the PTO shaft shields are in place and the shield rotation prevention chain is attached.

## POWER TAKE-OFF SHAFT



Tractor's PTO drive shaft dimensions should be 1 3/4" to maximize its operating life.

PTO shaft recommendations:

- Bondioli & Pavesi 10 (106 kW / 540 rpm) with overrunning clutch
- Walterscheid W2600 + F3 with overrunning clutch

An overrunning clutch must be mounted to the axle head on the chipper's power take-off.

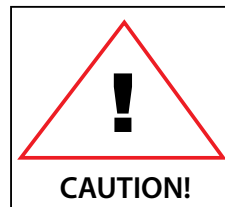

If the PTO shaft is too long it might damage chipper's bearings or the tractor's power take-off shaft when using the 3-point hitch. Shorten the both ends of PTO shaft equally.

# FARMI 381 HFC / HF

## SHORTENING THE PTO SHAFT

1. Connect the device to the tractor's 3-point hitch.
2. Lift the machine with the hitch so that the distance between the splined shafts is at its shortest.
3. First cut the thicker shaft shield to the correct length. Remember to leave a 40 mm clearance. Next, cut a similar length from the profile tube. Shorten the other half of the PTO shaft in a similar manner. File off the burr.
4. Interconnect the tubes and check that the shaft is sufficiently shortened by carefully lifting up and down with the hoist. Ensure that the shaft has a 40 mm movement clearance. Also move the machine sideways to check that the shaft moves freely.

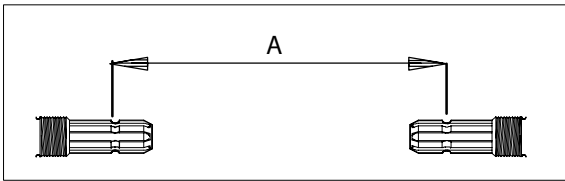

Distance A, when the distance between the splined shafts is at its shortest.

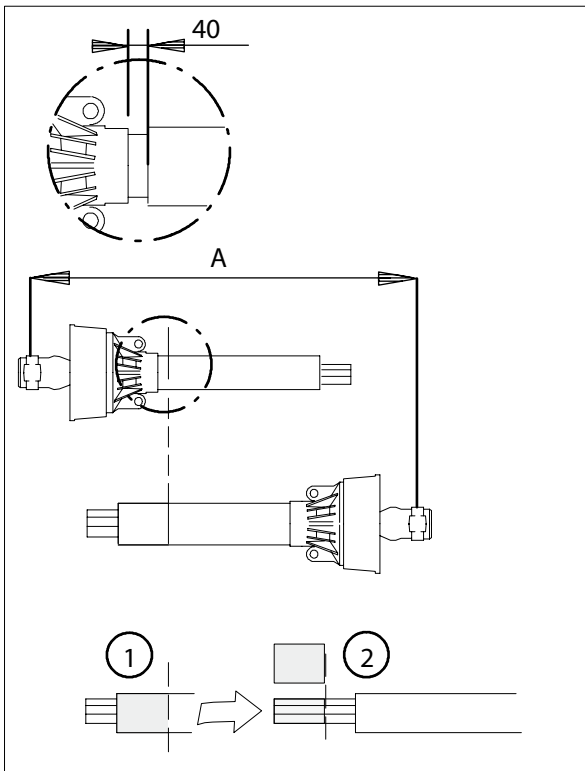

Shortening the PTO shaft

## MOUNTING THE FEED CHUTE

1. Fix the feed chute frame to the chipper with pins (A) and locking screws (B).
2. Fix the feed chute to the frame on both sides with pins (C) and cotter pins (D). Lock the chute in the operation position (E).

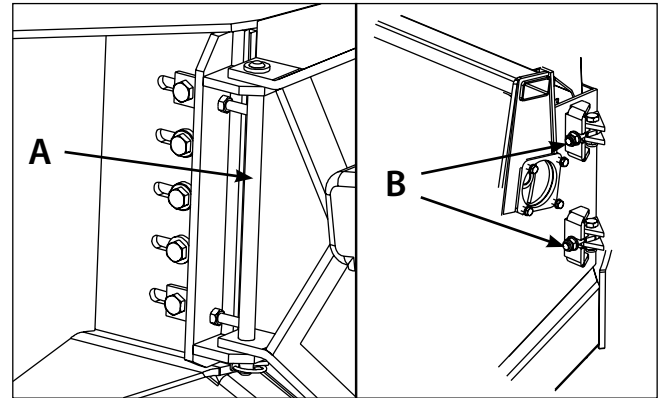

Fixing the feed chute frame to the chipper

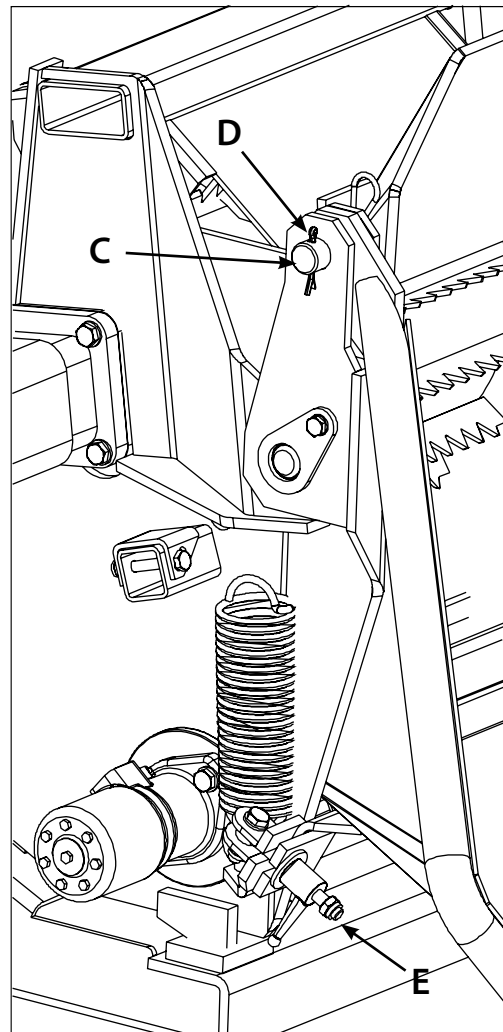

Fixing and locking the chute to the feed chute frame



# FARMI 381 HFC / HF

## OPERATION

### INSPECTION PRIOR TO USE

- Position the chipper on a level, hard surface.
- Carry out the inspection with the tractor engine switched off and the chipper disc fully stopped.
- Check that the disc rotates freely and that the chipper is free of any foreign objects.
- Check that all protective equipment is in place and in good condition. Do not remove any protective shields.



Check the oil level of the hydraulic oil reservoir. The oil level eyelet must be covered.

- Check the tightness of the hydraulic pump belt, see "Maintenance"
- Check the condition and tightness of hoses and couplings.

### CONTROL EQUIPMENT

The feed chute is operated from a remote control panel either with a manual switch or foot pedal.

1. STOP  
Feed rollers stop rotating.
2. FEED FORWARD = FF  
(Right-hand foot pedal)  
The feed rollers begin rotating inwards and wood can be fed into the chipper.
3. REVERSE = REV  
(Left-hand foot pedal)  
The feed rollers begin rotating outwards and wood can be removed from the rollers. The operating switch returns automatically to the STOP position.

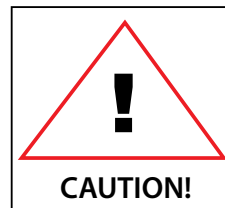

Do not operate in temperatures  $-20^{\circ}\text{C}$  due to the risk of cold brittleness damage which can occur in particular with the knife blades. Avoid chipping wood which has frozen through, as this weakens the self-feed function.



**ROTATING KNIVES!**  
Serious risk of cutting injury. Never place hands into the feed chute.



**FIRE HAZARD!**  
Always keep appropriate fire extinguishing equipment near to hand when using the chipper. Monitor the surface temperature of the chipper.

If the chipper begins to overheat, stop the chipper and investigate the cause. Monitor the temperature of the bearings. Carry out regular maintenance and keep the chipper clean of dust.

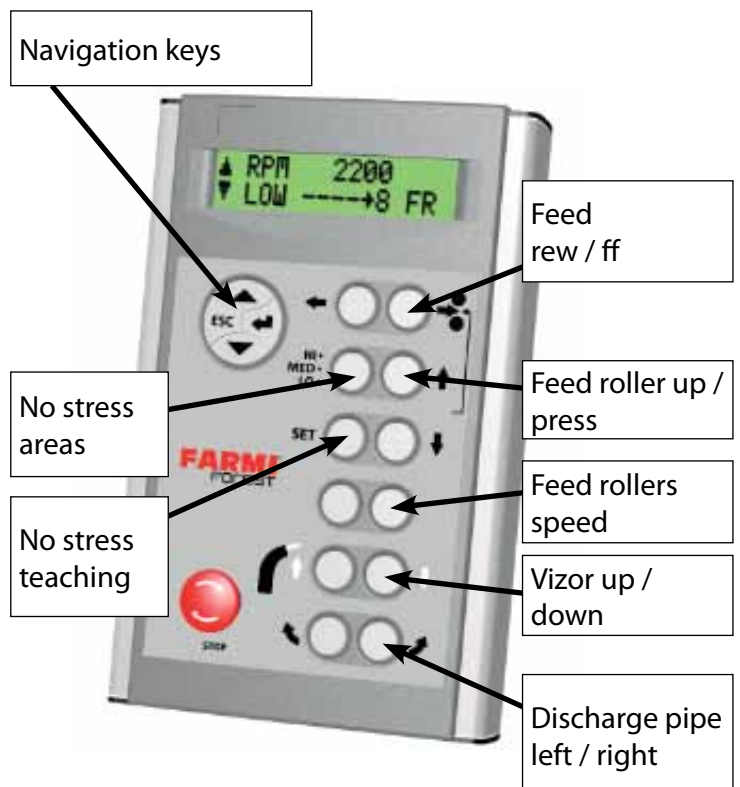

# FARMI 381 HFC / HF

## STARTING UP THE CHIPPER

1. Connect the chipper's power plug. Connect the hoses of the discharge pipe to the tractor hydraulics.
2. Lift and lock the top of the discharge pipe in place (1). Lift the discharge pipe to its operating position (2). Ensure the parts are locked in place.
3. Start the chipper with the tractor running at low rpm. Gradually bring the speed up to the level required for chipping. (540 / 1000 rpm).
4. Move the discharge pipe by moving the lever left or right. Adjust the lid position by moving the lever (A) up or down.
5. The directional positioning of the discharge pipe and the lid can only be performed while the chipper is running.

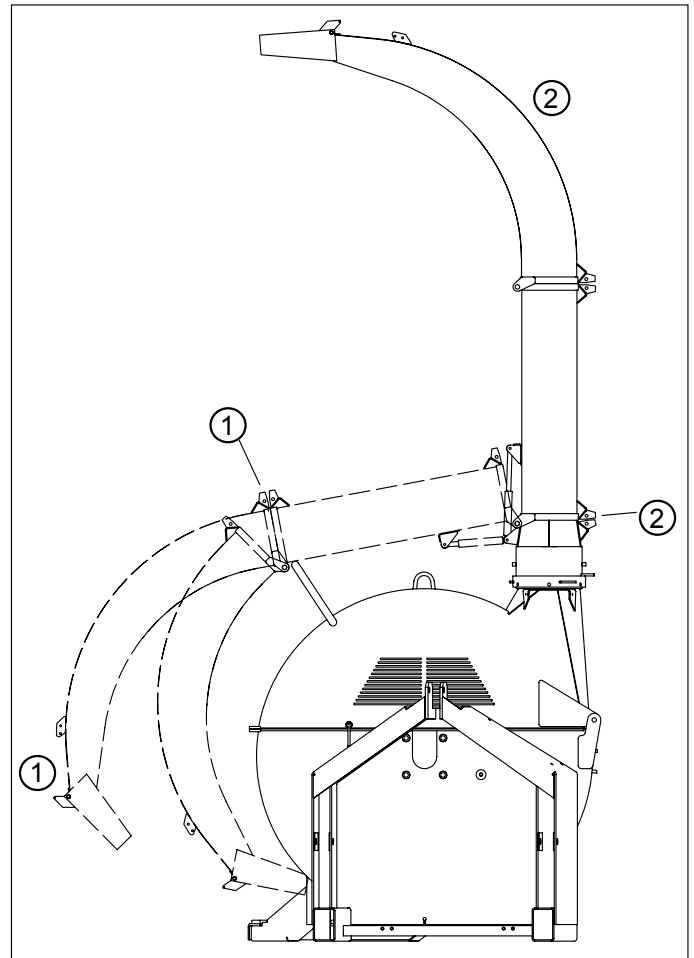

## STARTING THE TRACTOR PTO

Start the PTO in three steps:

1. Short start-up.
2. Even shorter start-up.
3. Let it rotate:

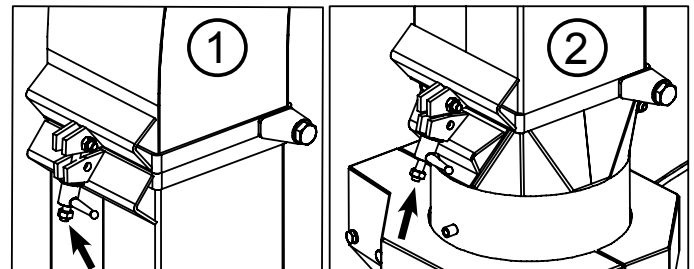

*Locking the discharge pipe parts*

# FARMI 381 HFC / HF

## NO STRESS SYSTEM

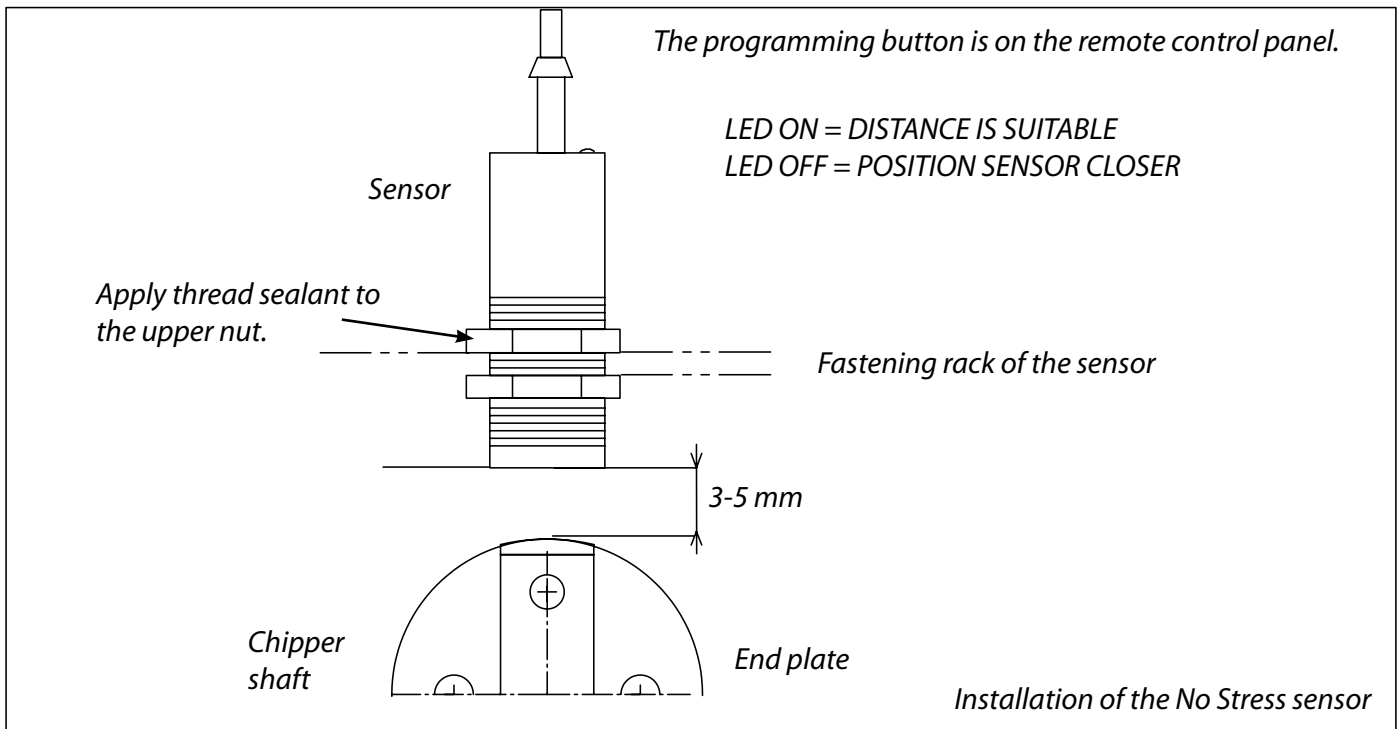
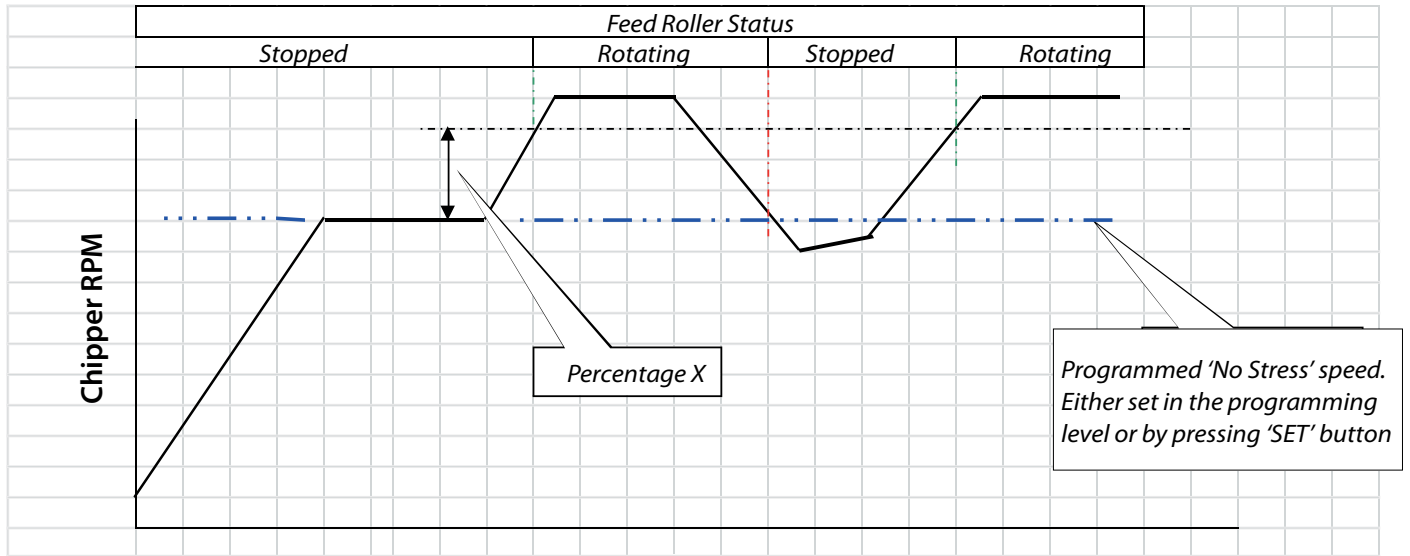

# FARMI 381 HFC / HF

## CHIPPING



FARMI FARM 381 HF/HFC is designed only for grapple loader feeding. The danger area radius is 20 m. Ensure that the danger area is clear of people.



Do not adjust the feed speed while feeding wood into the chipper. The valve can become damaged. Adjust the feed speed when the rollers rotate unloaded.

1. Make sure the feed chute is empty.
2. Turn the manual switch to the feed position FF (or press the right-hand foot pedal).
3. Check before feeding material into the chute that the material to be chipped contains no nails, stones etc.
4. Feed the wood into the chute using a grapple loader. Release the grapple as soon as the feed rollers begin to draw in the wood.
5. If necessary, adjust the rotational speed of the feed rollers, see the section "Feed speed control".
6. Discontinue feeding while adjusting the discharge direction.
7. If you need to remove wood from the feed chute in the middle of chipping, turn the manual switch to the reverse position REV (left foot pedal). Keep the switch in the REV position until the feed roller releases the wood.



Oil heats up as it circulates through the hydraulic pump, motor and valves. Check the oil temperature twice each hour to prevent overheating. If the oil heats excessively, stop chipping and allow the oil to cool.

## STOPPING THE CHIPPER VIA THE TRACTOR DRIVE

Slow the tractor rpm to idling speed before disengaging the PTO. Move the PTO control lever slowly to the OFF position.

# FARMI 381 HFC / HF

## CHIPPER TRANSPORTATION

Before transporting the unit, turn the discharge pipe parallel with the upper chamber and lower it.



Take extreme care when turning the discharge pipe!

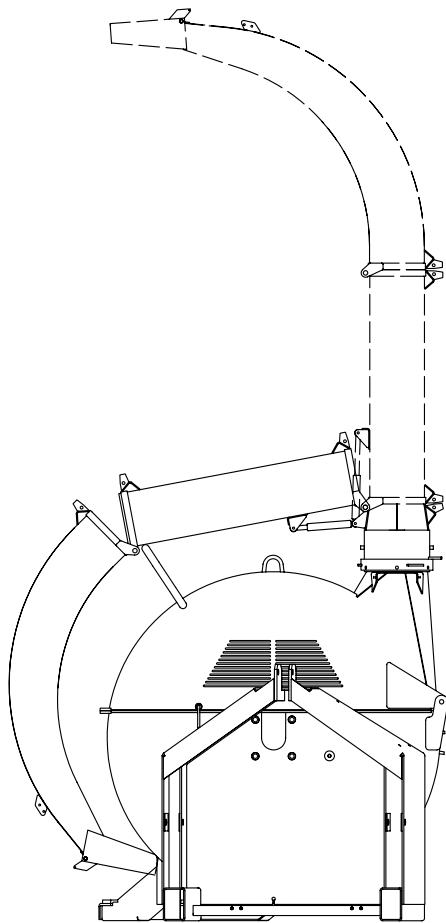

*Transportation position*

## STORAGE

- Ensure that the chipper is stored on a solid surface and is unable to topple over.
- If the chipper has been left unused for a prolonged period, lubricate the knives e.g. with Vaseline.
- Ensure that the water drainage holes in the lower chamber are open.

# FARMI 381 HFC / HF

## MAINTENANCE

### GENERAL MAINTENANCE INSTRUCTIONS



Position the chipper on solid, level ground to safeguard against toppling. Always disconnect the power-take-off and stop the chipper and tractor fully before embarking on maintenance or repair work. The chipping disc

continues to rotate freely in the manner of a fly-wheel after the power take-off has been disconnected.

**WAIT UNTIL THE DISC COMPLETELY STOPS ROTATING!**

Lock the disc in place before commencing maintenance and repair work.

Wear eye protection when handling the knives.

### PTO SHAFT LUBRICATION

- Grease the PTO shaft before operating and at regular intervals as shown in the diagram.
- Grease the inner surface of the outermost PTO shaft profile drive tube.
- In winter, grease the shaft shield tubes to prevent freezing.

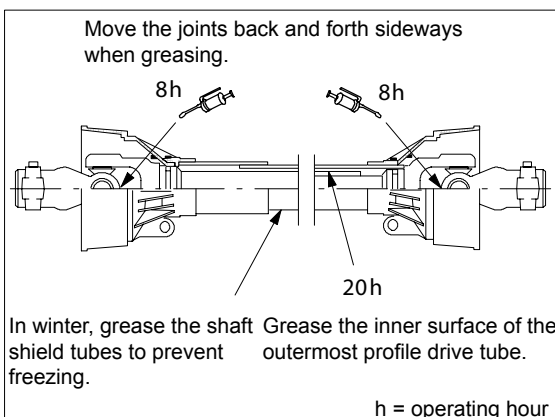

*PTO shaft greasing points and greasing intervals*

## PERIODIC INSPECTIONS

- The tightness of the fastening bolts of a brand new chipper must be checked after the first operating hour and tightened as necessary. Tightening torques as shown in the table.
- The tightness of fastening bolts should be checked on a weekly basis.
- The knife clearances must be adjusted in accordance with the given values. See the Knife Clearance Adjustment instructions.
- Bearings are factory greased. Use high quality grease for post-lubrication.
- The feed roller bearings are self-lubricating and do not require regular maintenance.
- Grease the joint bearings of the roller swing at intervals of 50 operating hours.
- Grease the disc bearings at intervals of 50 operating hours.
- Regularly monitor the condition and connection tightness of the hydraulic hoses.
- Only use clean oil in the hydraulic system. Dirty oil damages valves and hydraulic motors.

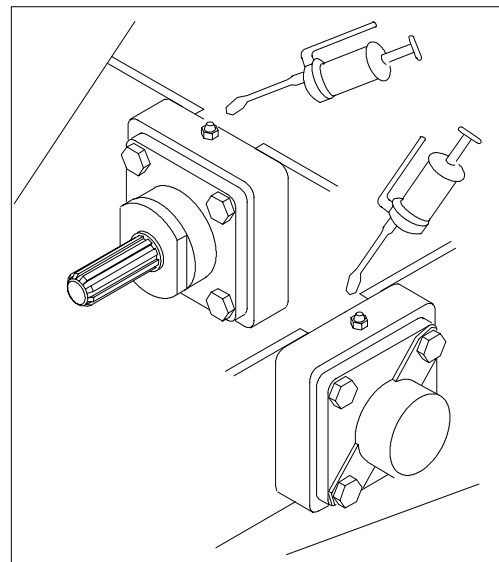

*Bearing lubrication*

# FARMI 381 HFC / HF

## MAINTENANCE

ITEM	ACTION	MAINTENANCE INTERVAL	NOTES
Chipper frame and knife units	Tighten pins and nuts	Weekly	All pins and nuts must be tightened after the first operating hour! For the torques, see the table.
	Check twig breaker and additional knife	At the time of knife maintenance	Check the twig breaker and the additional knife for breakage.
Hydraulic system	Replacement of the return filter	500 h	
	Oil change	1500 h	First oil change after 80 operating hours!
	Check timing belt	250 h	If necessary, tighten according to instructions.
	Check hydraulic hoses and joints	Daily	
Grease nipple:			
1. PTO drive shaft	Lubricate	Daily	See separate instructions
2. Rotor bearing	Lubricate	50 h	5-6 pump strokes / bearing
3. Swing bearing of the roller swing	Lubricate	50 h	
4. Lifting cylinder of the roller swing	Lubricate	50 h	
5. Bearing of the material feed	Lubricate	50 h	
6. Opening cylinder of the upper housing	Lubricate	250 h	
7. Swiveling cylinder of the discharge pipe	Lubricate	250 h	
8. Lifting cylinder of the material feed	Lubricate	250 h	
Electrical system	Check lines and connectors.	Weekly	
	Lubricate electrical connectors	250 h	Spray anti-oxidant onto the connectors.
Feed unit	Check the tension of the feed unit.	50 h	If necessary, tighten according to instructions.
	Check the sliding plates for damage.	50 h	

# FARMI 381 HFC / HF

## MAINTENANCE POINTS

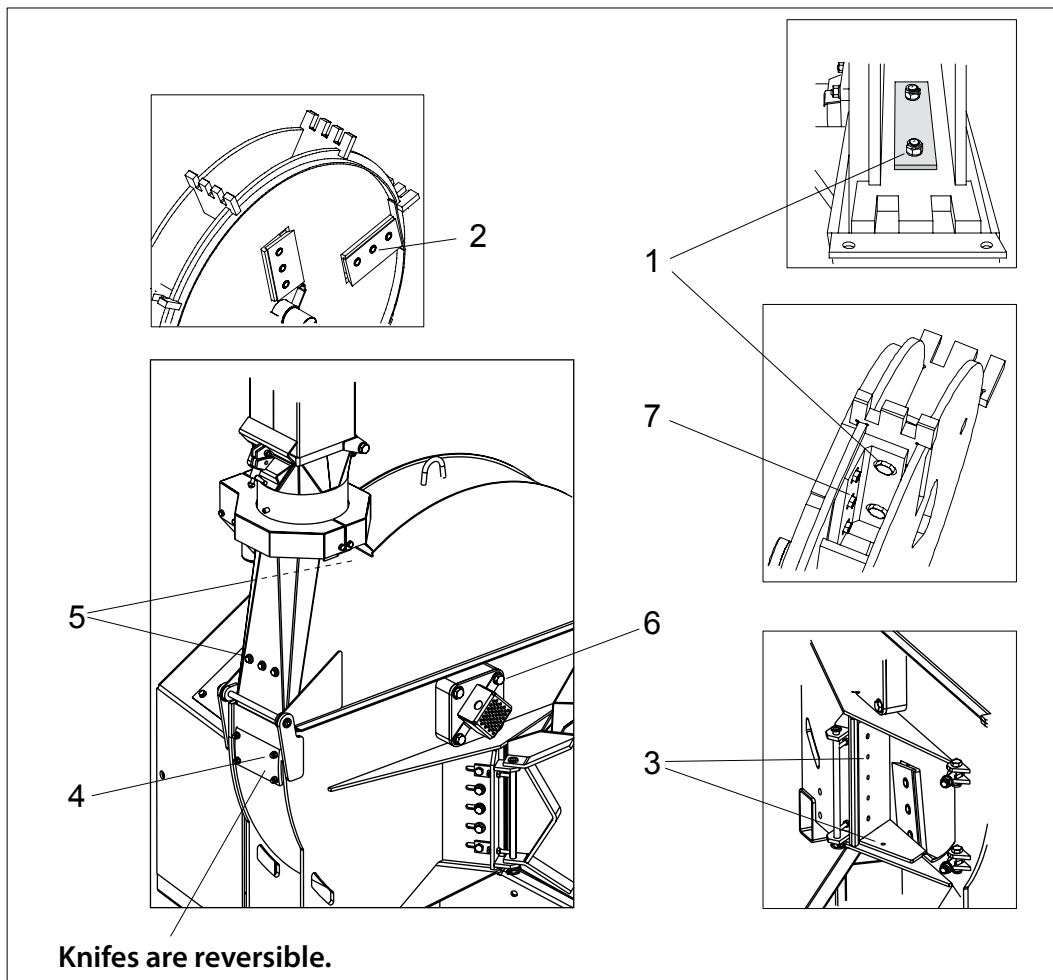

### Tightening points

Maintenance point	Width across flats, mm	Tightening torque, Nm
1. Tightness of knife holder fastening bolts	36	1000
2. Tightness of knife fastening bolts	22	120
3. Tightness of anvil fastening bolts	24	200
4. Tightness of twig breaker fastening bolts	19	80
5. Breaker fastenings	19	80
	24	170
6. Tightness of bearing fastening bolts	30	300
7. Tightness of knife fastening bolts	22	100



# FARMI 381 HFC / HF

## TENSION OF THE TIMING BELT

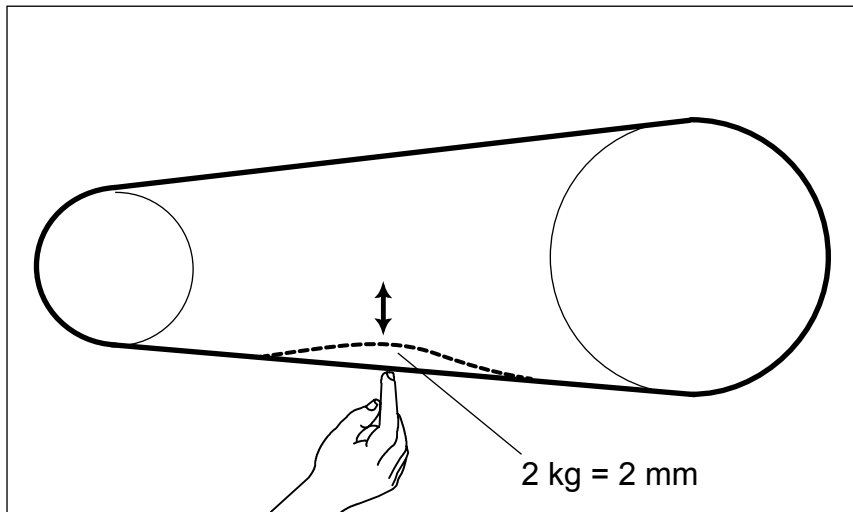

## TENSION OF THE FEED UNIT

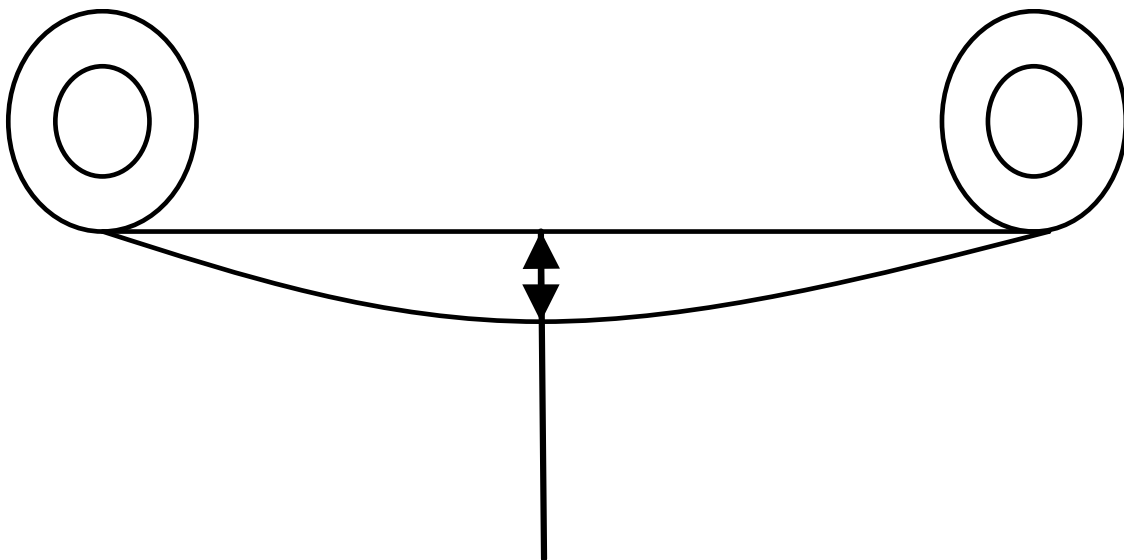

In feeding position, i.e. when the belt is tight, there must be a clearance of 3 - 5 cm below the belt.

## LUBRICANT TABLE

ITEM	OIL TYPE/GRADE	QTY
Hydraulic system	summer: TEBOIL Hydraulic oil 46 S or equivalent (ISO VG46S) winter: TEBOIL Hydraulic oil 32 S or equivalent (ISO VG32S)	approx. 75 l
Bearing	TEBOIL Multipurpose Grease or equivalent	
Electrical connectors	Multi-purpose oil CRC 5-56 or equivalent	

# FARMI 381 HFC / HF

## MAINTENANCE

### KNIFE MAINTENANCE



Please refer to the safety instructions. The chipping disc continues to rotate freely in the manner of a flywheel after the power take-off has been disconnected.

Use protective gloves when handling the knives.

### OPENING AND REMOVAL OF THE UPPER CHAMBER

- Remove the M16 (3 pcs) locking screws.
- Turn the upper chamber onto its side.
- Lock the disc with the locking bolt.
- Remove the feed chute or turn it to the side.

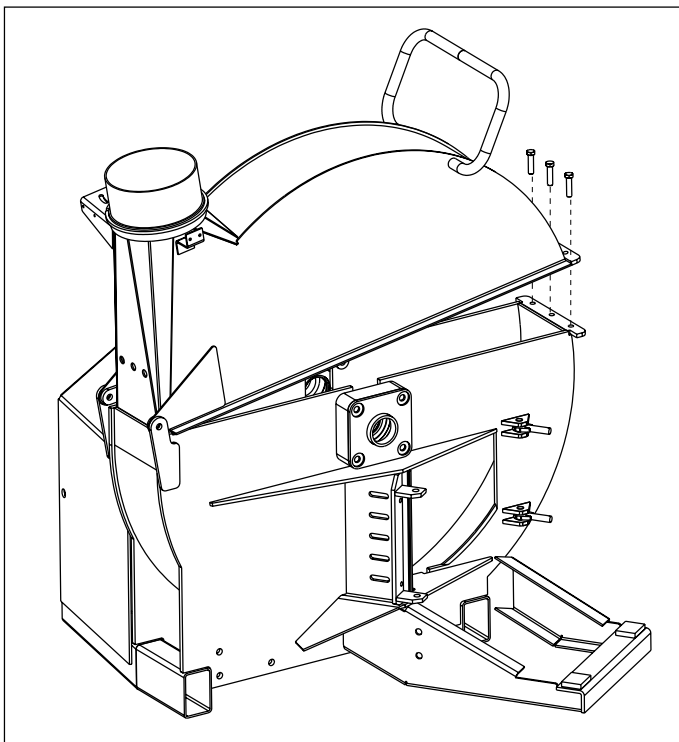

Opening the upper chamber

### KNIFE REMOVAL FROM THE KNIFE HOLDERS

1. Remove the knife's lock nuts (M14).
2. Remove the knife fastening bolts (M14). Turn the wrench carefully to avoid hand injury by the knife should the wrench slip.

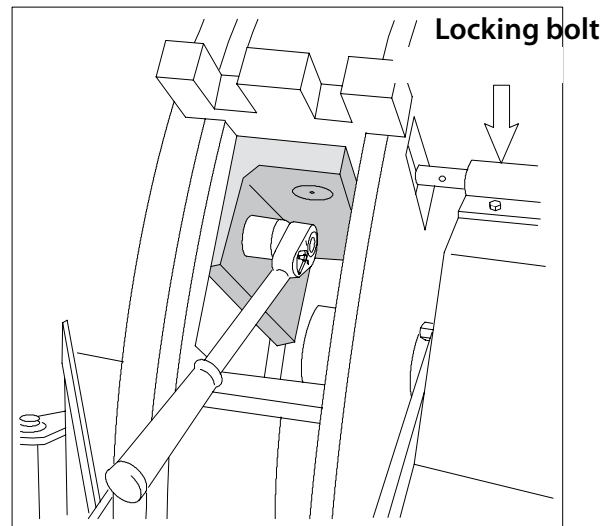

Locking the disc and removing the lock nuts

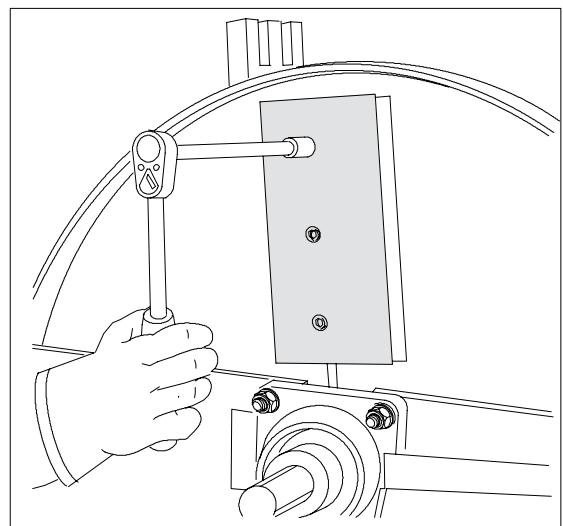

Removing the knife fastening bolts

# FARMI 381 HFC / HF

## BLADE SHARPENING

Sharpen all blades equally. This ensures disc balance. Avoid heating the blades during grinding.

Indications that the knife blades need sharpening are:

- self-feed is less effective.
- increased power demand.
- cut surface of the chip is rough.

Normally, the knives can be sharpened a number of times in situ (grindstone, belt grinder) before complete removal becomes necessary.

Thorough reconditioning, however, requires blade removal and use of a knife grinder.

The new knives are sharpened to a concave shape,  $R=200$ . The sharpening angle is  $30^\circ$  and the hone angle  $45^\circ$ . The hone angle prevents the blade edge from breaking.

It is recommended that post-sharpening of the knives is also performed to a concave shape. If this is not possible, sharpen the knives to a flat profile.

Grind the hone angle at  $45^\circ$  with two to three longitudinal strokes, using a level sharpening stone. Remove the burrs from the knife fastening bolt side by grinding along the blade surface.

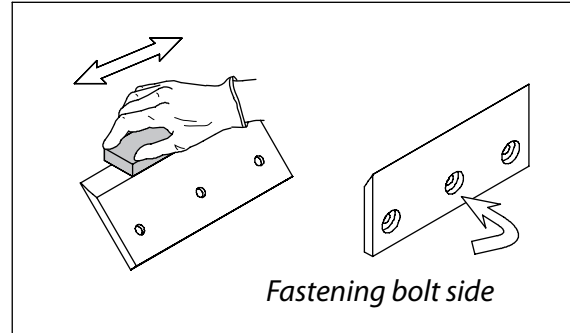

Final knife grinding

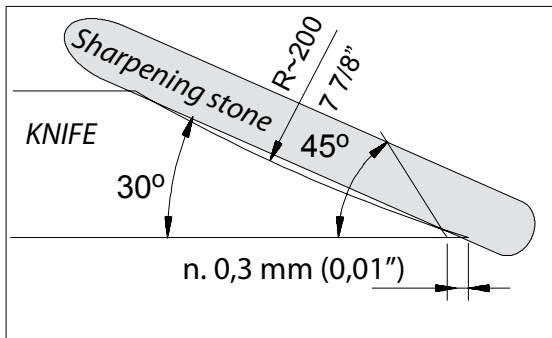

Concave blade profile

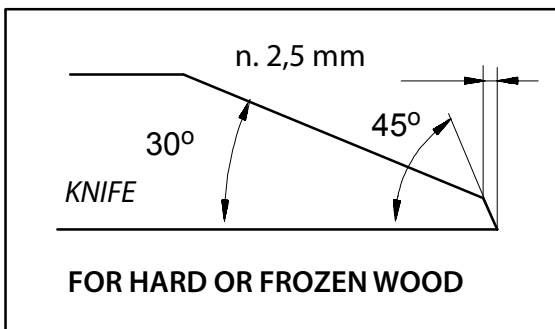

Flat blade profile

## REMOVING THE ANVILS

The chipper is equipped with both vertical and horizontal anvils. To remove the anvils, open the fastening bolts (A) and (B). The horizontal anvil fastening bolt (B) is located below the feed opening.

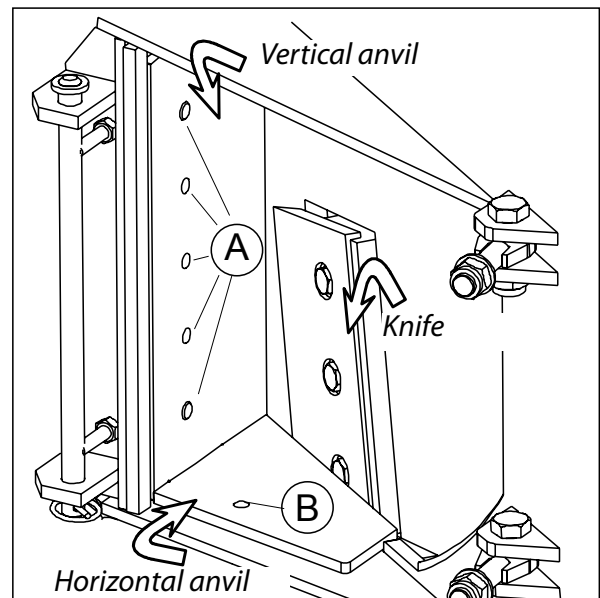

Anvil fastening bolts

# FARMI 381 HFC / HF

## SHARPENING THE ANVILS

If you notice wear or rounding of the inner edge of the anvil, sharpen the anvils so that the original angles are retained.

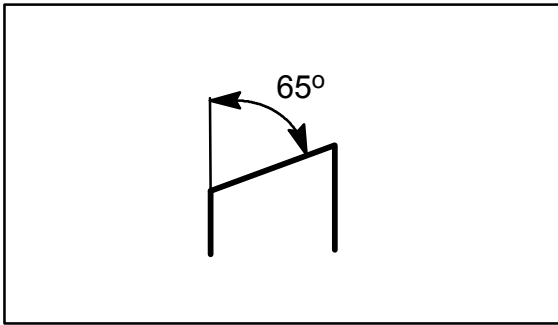

Vertical anvil profile

## INSTALLING THE ANVILS

- Check the condition of the knife fastening bolts and nuts.
- Install the knives and tighten the fastening bolts to the torques specified in the torque table.
- Adjust the knife-to-anvil clearance.

## KNIFE-TO-ANVIL CLEARANCE ADJUSTMENT AND INSPECTION

The amount of anvil adjustment required is determined by the amount the knives are sharpened. Always check and, if necessary, adjust the clearance between the knives and anvils:

- after a heavy sharpening
- whenever the knives are removed, e.g. for sharpening
- whenever knives are replaced
- when changing the chip length.

Use a feeler gauge to check and adjust the clearance.

- Turn the disc so that the knife edge is aligned with the vertical anvil.
  - Measure the clearance and adjust as necessary.
1. Remove the fastening bolts of the vertical anvils M16 (A).
  2. Adjust the knife-to-vertical anvil clearance with the adjusting nuts (M12) (C) to 1.5 mm.
  3. Tighten the adjusting screw nuts M12. Tighten the anvil fastening bolts to 200 Nm.
  4. Check that the blade clearance of all knives is the same.

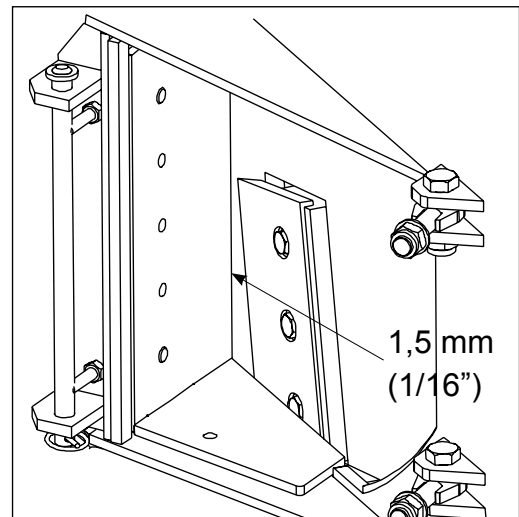

Blade clearance

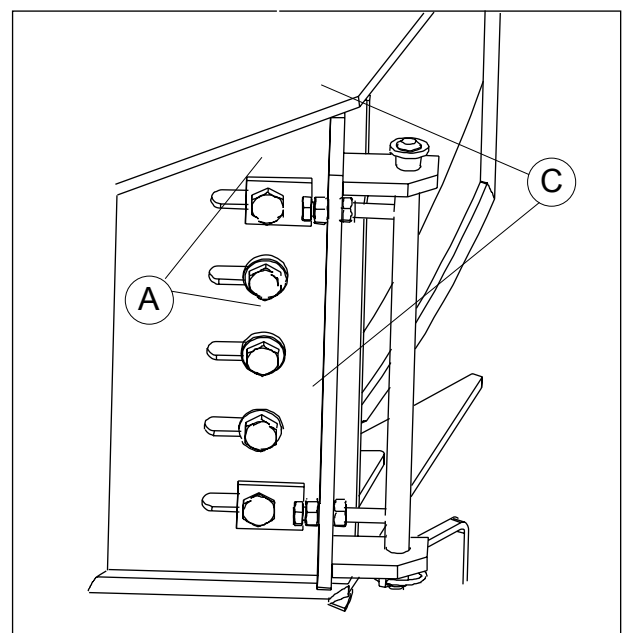

Installation and adjustment of anvils

# FARMI 381 HFC / HF

## WIPER KIT

### Instructions for adjusting the wiper plates:

- Adjust cutting blades to the required chip size.
- Adjust anvils.
- Adjust the wiper plates to the same plane with the knives. Leave 2 mm gap between the cutting blade and the wiper. Also make sure that there is a 1-3 mm gap between the wiper plates and the circular plates.

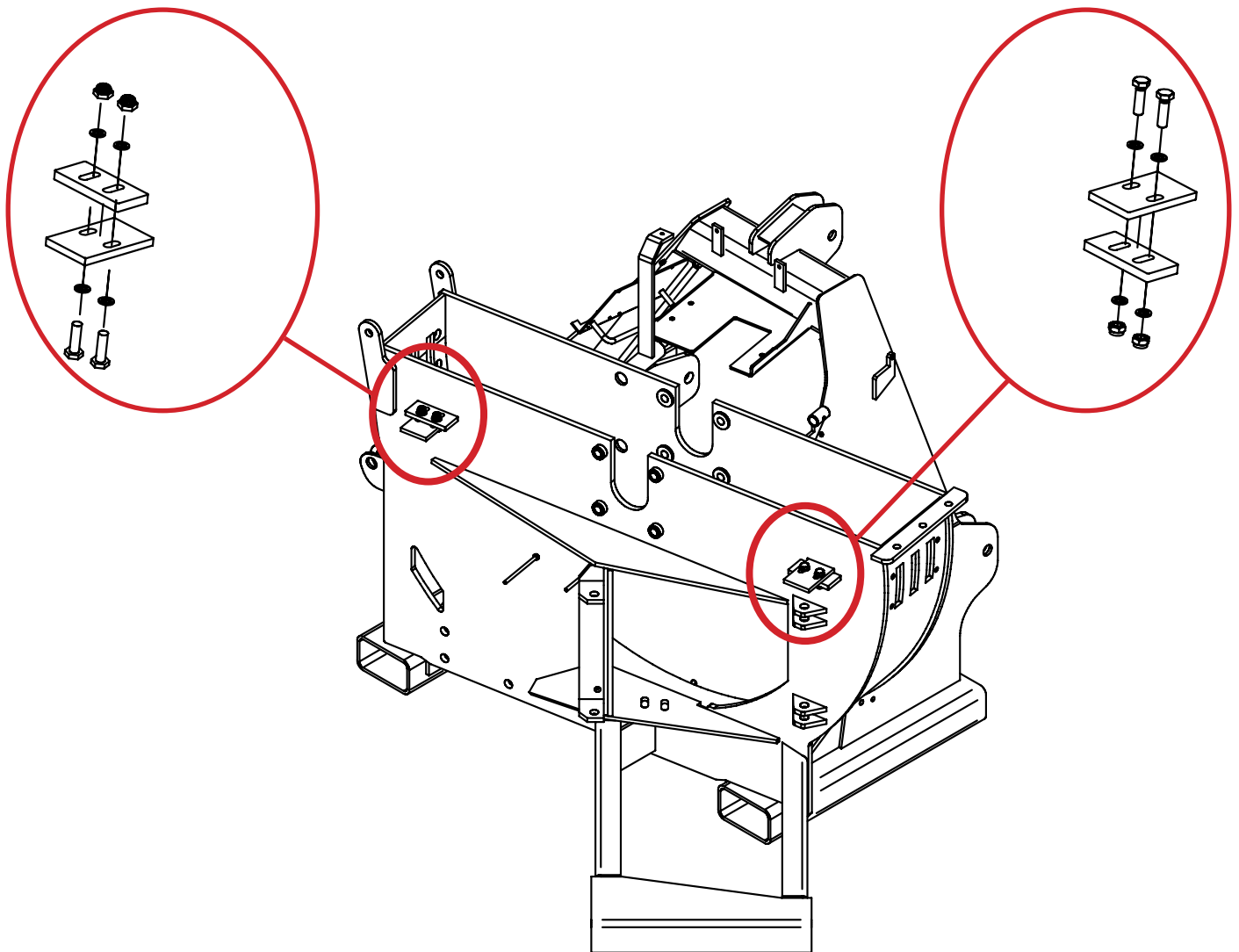

## CHIP LENGTH ADJUSTMENT

Chip length is determined by the distance between the knives and the disc. Chip length is adjusted by moving the knife holders. The chip length can range between 10-30 mm.

1. Firstly, follow the "Opening and removal of the upper chamber" instructions.
2. To extend the chip length, first remove the anvil fastening bolts M16 (A)
3. Move the anvils further from the disc.
4. Remove the knife holder fastening nuts, M24. Set both ends of the knives to the same distance from the disc. Use the adjustment screws for this purpose.
5. Tighten one of the knife holder nuts and re-check the distance measurement at the other end.

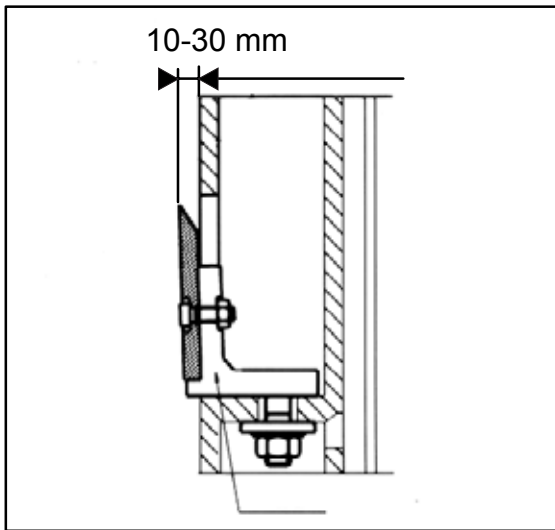

*Chip length adjustment*

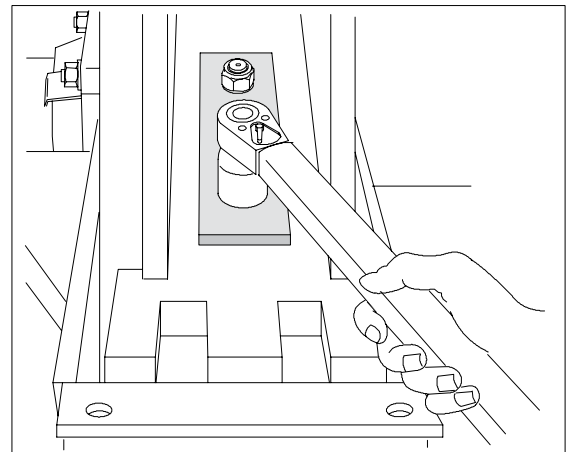

*Removing the knife holder nuts*

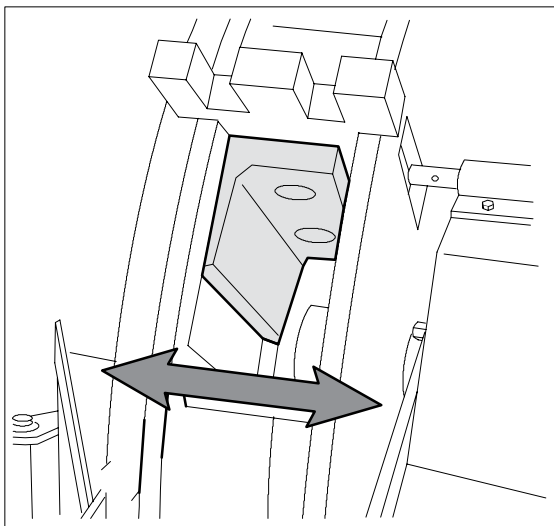

*Knife holder adjustment direction*

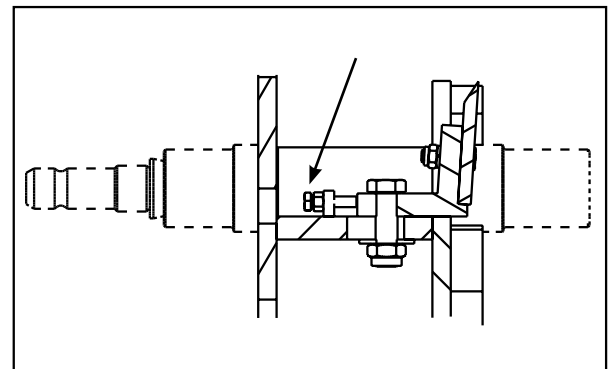

*Knife holder adjustment screw*

## SPLINED SHAFT REPLACEMENT

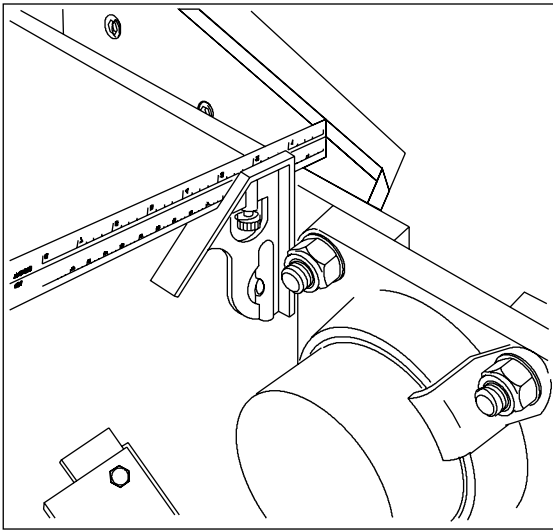

Guide measurement

1. Remove the upper chamber.
2. Remove the bearings (see figure "Bearings installation"). Welding damages the bearings.
3. Hoist up the disc.
4. Grind a 25 mm deep groove about 2 mm from the edge of the shaft. See the illustration.
5. Heat the joint area if necessary.
6. Move the splined shaft first to loosen it, then remove it.
7. Clean the shaft hole and carefully fit the new shaft in place.
8. Make an 8 mm fillet weld in three runs. Use ESAB 68.81, K 48, OK Femax 38.65, or equivalent filler.

Adjust the remaining knives as follows:

1. Take the guide measurement from both ends of the knife you have just positioned. The guide measurement is the distance between the knife edge and the chamber.
2. Adjust the remaining knives using the guide measurement so that the guide measurement.
3. Tighten the knife holder fastening bolts to 450 Nm.
4. Carry out a measurement check of all knives.
5. Check the knife clearances in accordance with the "Knife clearance adjustment and checking" instructions.

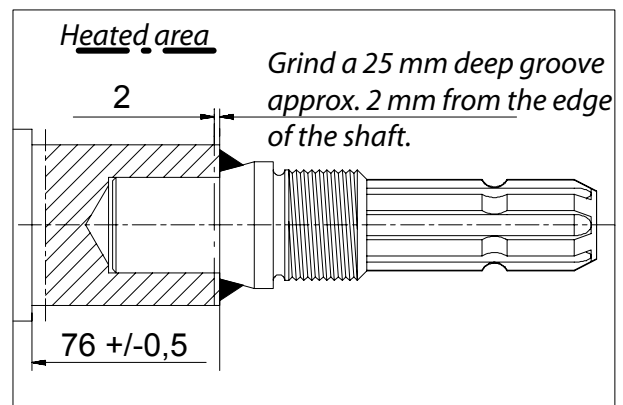

Replacing the splined shaft

# FARMI 381 HFC / HF

## CHIPPER

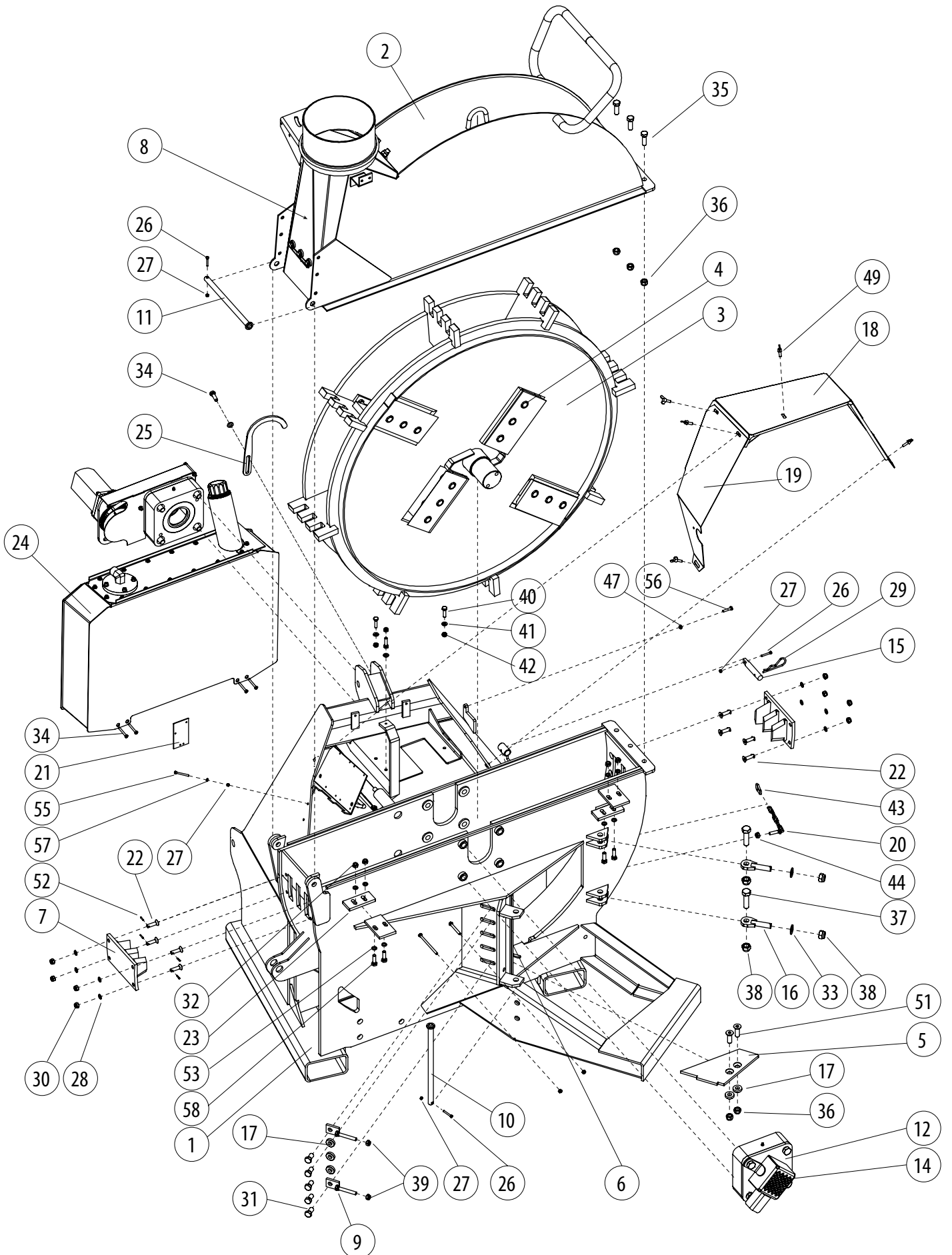



# FARMI 381 HFC / HF

## CHIPPER

Part	Order no	Description	Remarks	Qty
1	33802410	Lower chamber		1
2	33800030	Upper chamber		1
3	03800100	Rotor, complete	see separate spare part page	1
4	43803060	Knife		4
5	43802350	Horizontal anvil		1
6	43802360	Vertical anvil		1
7	43801510	Twig blade		2
8	03801160	Twig crusher	see separate spare part page	1
9	43291103	Anvil adjuster		2
10	43801650	Hinge pin		1
11	43801670	Hinge pin		1
12	03801900	Bearing unit, complete	see separate spare part page	2
13	-	-	-	-
14	43804130	No Stress -frame		1
15	43801590	Pin	L150	1
16	43802460	Lock nut		2
17	43292739	Washer		6
18	43805400	Air guide plate		1
19	43805410	Electric box cover		1
20	43804120	Locking chaine		1
21	43806100	Fastening for three-way valve		1
22	43805370	Fastening screw		8
23	43294420	Wiper		2
24	03803000	Hydraulic unit	see separate spare part page	1
25	43806340	Hook for universal shaft		1
26	52060050	Screw	M6X40 DIN933 88ZN	3
27	52117066	Lock nut	M6 DIN985 8ZN	3
28	52214269	Locking washer	M12 NORD-LOCK	8
29	52842143	Cotter	5X105	1
30	52117124	Lock nut	M12 DIN985 8ZN	8
31	52062106	Screw	M16X30 DIN933 88ZN	5
32	52062262	Screw	M20x100 DIN931 88ZN	8
33	52200086	Washer	M20 DIN126 58ZN	2
34	52062031	Screw	M12X40 DIN933 88ZN	5
35	52062122	Screw	M16X50 DIN933 88ZN	3
36	52117165	Lock nut	M16 DIN985 8ZN	5
37	52062247	Screw	M20X70 DIN931 88ZN	2
38	52117207	Lock nut	M20 DIN985 8ZN	4
39	52110053	Nut	M12 DIN934 8ZN	4
40	52060258	Screw	M10X40 DIN933 88ZN	3
41	52200045	Washer	M10 DIN125 58ZN	3
42	52117108	Lock nut	M10 DIN985 8ZN	3
43	53804135	Spring hook	DIN 5299C, 6x60	1

# FARMI 381 HFC / HF

## CHIPPER

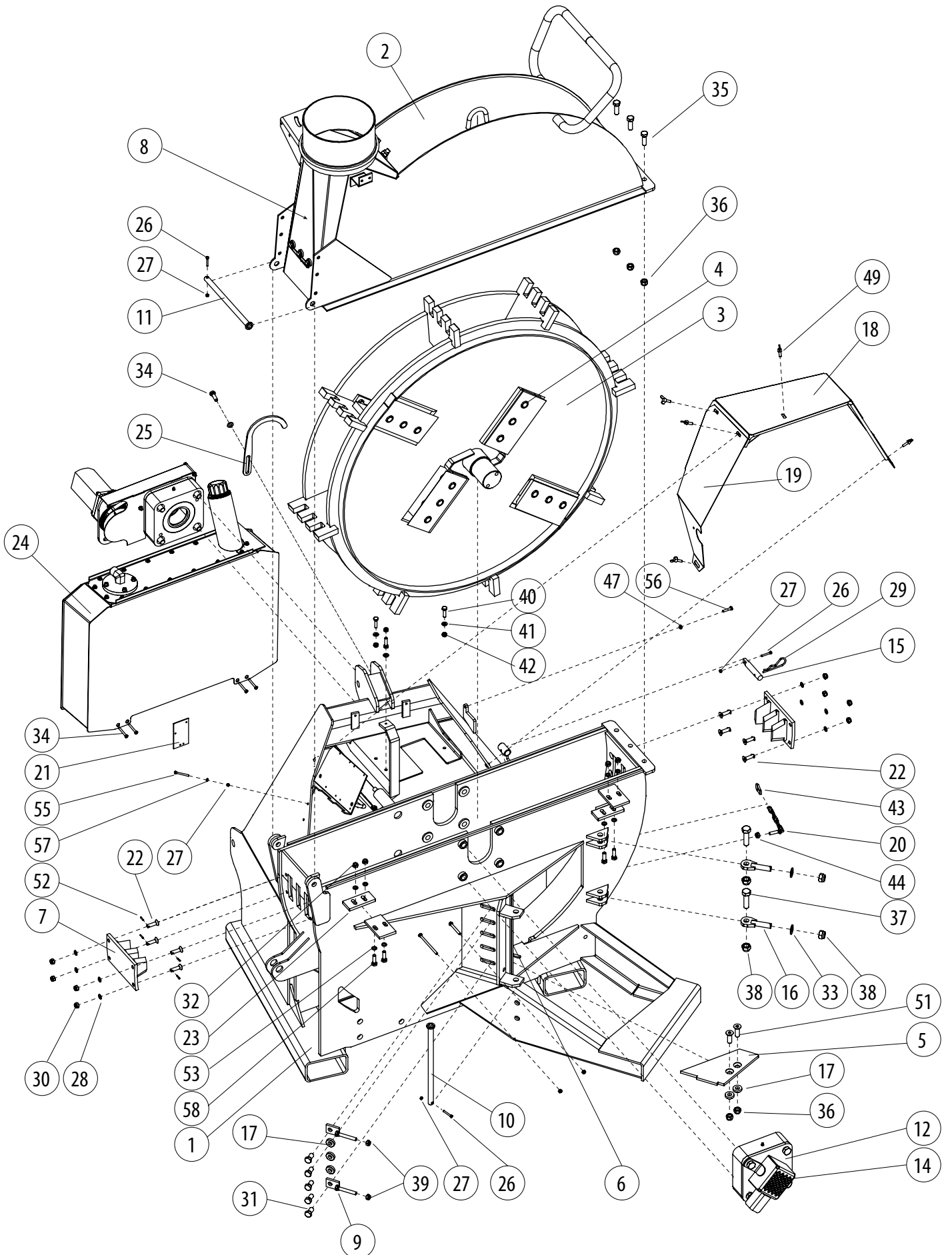

# FARMI 381 HFC / HF

## CHIPPER

Part	Order no	Description	Remarks	Qty
44	52110046	Nut	M10 DIN934 8ZN	2
45	52211083	Spring washer	M20 DIN127 ZN	8
46	52090702	Hexagon socket countersunk head cap screw	M8X90 DIN7991	4
47	52117082	Lock nut	M8 DIN985 8ZN	5
48	52062840	Eyebolt	M12X120 88ZN	1
49	52117930	Wing screw	M8X25 DIN316	8
50	-	-	-	-
51	52090694	Hexagon socket countersunk head cap screw	M16x50 DIN7991	2
52	52813011	Split pin	2X15 DIN94 ZN	8
53	52200052	Washer	M12 DIN125 58ZN	8
54	52200582	Washer	M12 DIN9021 58ZN	2
55	52001559	Hexagonal socket head screw	M6X60 DIN912 88ZN	1
56	52070406	Screw	M8x35 DIN931 88ZN	1
57	52200029	Washer	M6 DIN126 58ZN	1

# FARMI 381 HFC / HF

## KNIFE, ROTOR AND BEARING UNIT

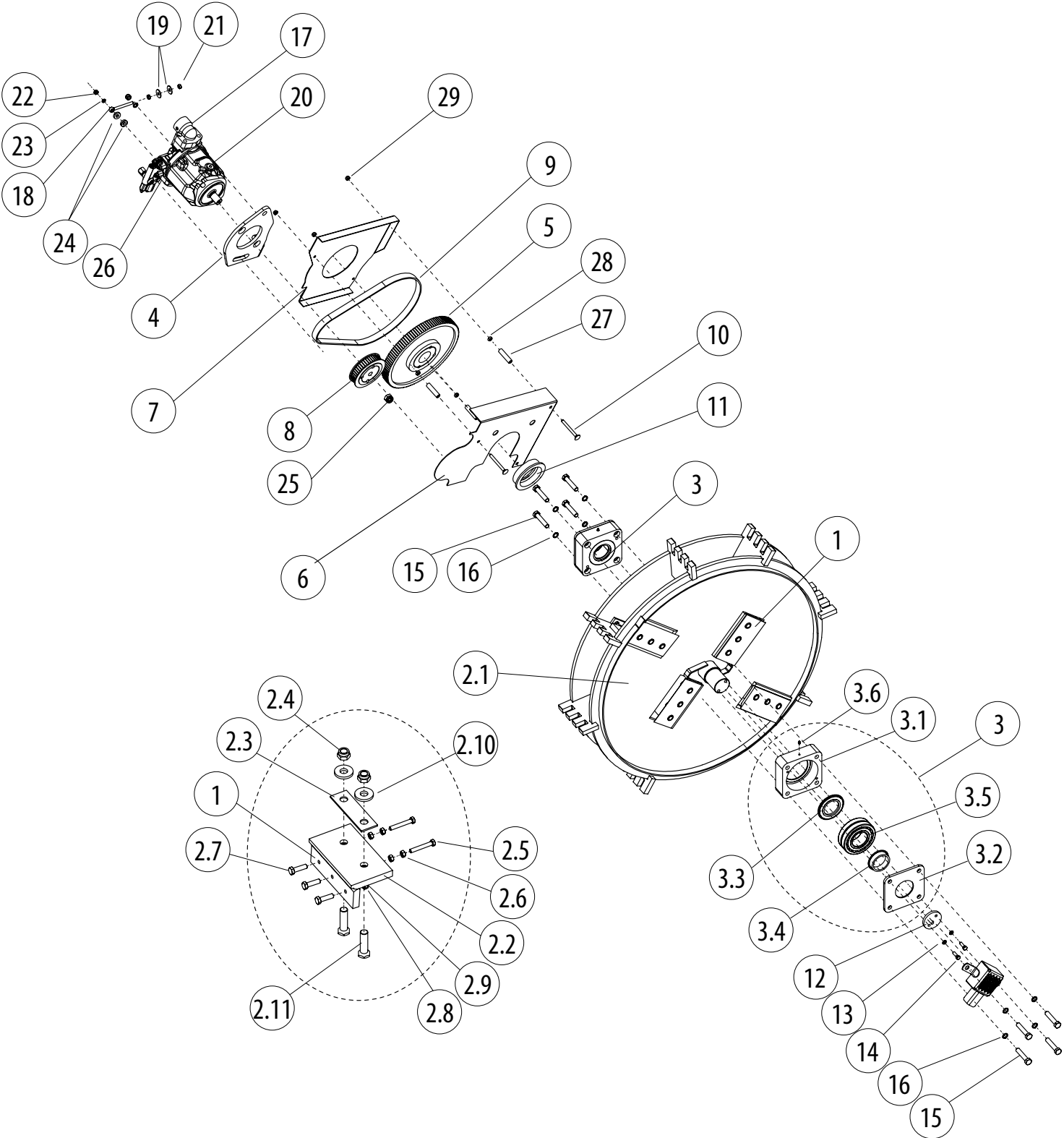

# FARMI 381 HFC / HF

## KNIFE, ROTOR AND BEARING UNIT

Part	Order no	Description	Remarks	Qty
1	43803060	Knife		4
2	03810990	Rotor	complete	1
2.1	43800100	Rotor		1
2.2	43811020	Knife bracket		4
2.3	43800750	Support plate		4
2.4	52117231	Lock nut	M24x2 DIN985 10.9	8
2.5	52063340	Screw	M12X80 DIN933 88ZN	8
2.6	52110053	Nut	M12 DIN934 8ZN	6
2.7	52090933	Screw	M14x50 DIN931 10.9	12
2.8	52211067	Spring washer	M14 DIN127 ZN	12
2.9	52117140	Lock nut	M14 DIN985 8ZN	12
2.10	52200660	Washer	M24 DIN6340 ZN	8
2.11	52063872	Screw	M24x80x2 DIN960 10.9	8
3	03801900	Bearing unit	complete	2
3.1	43800590	Bearing housing		1
3.2	43800600	Bearing housing cover		1
3.3	43800610	Labyrinth ring		1
3.4	43800620	Labyrinth sleeve		1
3.5	54523213	Spherical roller bearing		1
3.6	52401015	Grease nipple	AR1/8	1
4	43811030	Pump fastening plate		1
5	43806810	Belt pulley	Z=112	1
6	43806830	Belt cover's fastening plate		1
7	43806860	Belt cover's protection plate		1
8	03806820	Belt pulley	Z=45	1
9	53220620	Belt		1
10	52021200	Locking bolt	M8X80 DIN603 88ZN	3
11	43806720	Labyrinth sleeve		1
12	43802560	End plate		1
13		Lock washer	M12 NORD-LOCK	2
14	52062031	Screw	M12X40 DIN933 88ZN	2
15	52062262	Screw	M20x100 DIN931 88ZN	8
16	52211083	Spring washer	M20 DIN127 ZN	8
17	52427820	Flange		1
18	52062840	Eyebolt	M12X120 88ZN	1
19	52200582	Washer	M12 DIN9021 58ZN	2
20	56057390	Pump		1
21	52110053	Nut	M12 DIN934 8ZN	2
22	52117124	Lock nut	M12 DIN985 8ZN	1
23	52214269	Lock washer	M12 NORD-LOCK	1
24	43292739	Washer		2
25	52117249	Lock nut	M24 DIN985 8ZN	1
26	52427830	Flange		1
27	43806850	Bushing		3
28	52110038	Nut	M8 DIN934 88ZN	3
29	52117082	Lock nut	M8 DIN985 8ZN	3

# FARMI 381 HFC / HF

HYDRAULIC UNIT HD381

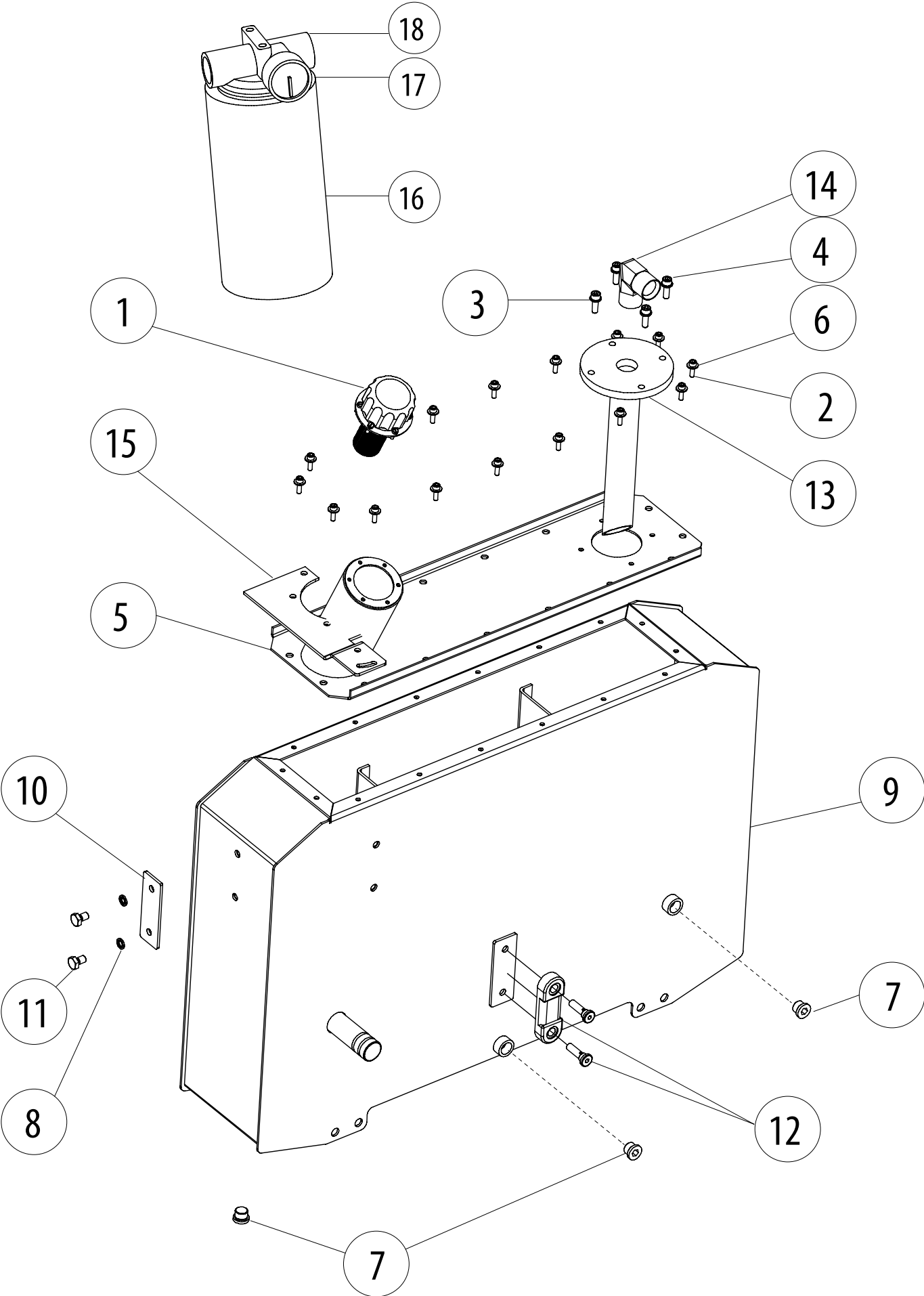

# FARMI 381 HFC / HF

## HYDRAULIC UNIT HD381

Part	Order no	Description	Remarks	Qty
1	56017536	Filler filter		1
2	52001062	Hexagonal socket head screw	M6X20 DIN912 88ZN	16
3	52200037	Washes	M8 DIN126 58ZN	4
4	52001260	Hexagonal socket head screw	M8X25 DIN912 88ZN	4
5	33811060	Cover		1
6	52200037	Washer	M8 DIN126 58ZN	16
7	52080190	Plug		3
8	52390515	Usit-ring	U10,37X15,88X2,03	2
9	43802800	Tank		1
10	43806090	Plate		2
11	52060209	Screw	M10X16 DIN933 88ZN	2
12	52460460	Level gauge-thermometer		1
13	43806880	Flange		1
14	52442373	Angle nipple	RK1 - R1	1
15	43806910	Filter fastening plate		1
16	56047570	Filter		1
17	56047560	Manometer		1
18	56047580	Return oil filter		1

# FARMI 381 HFC / HF

03805700 DISCHARGE PIPE, COMPLETE from serialnumber 3800100

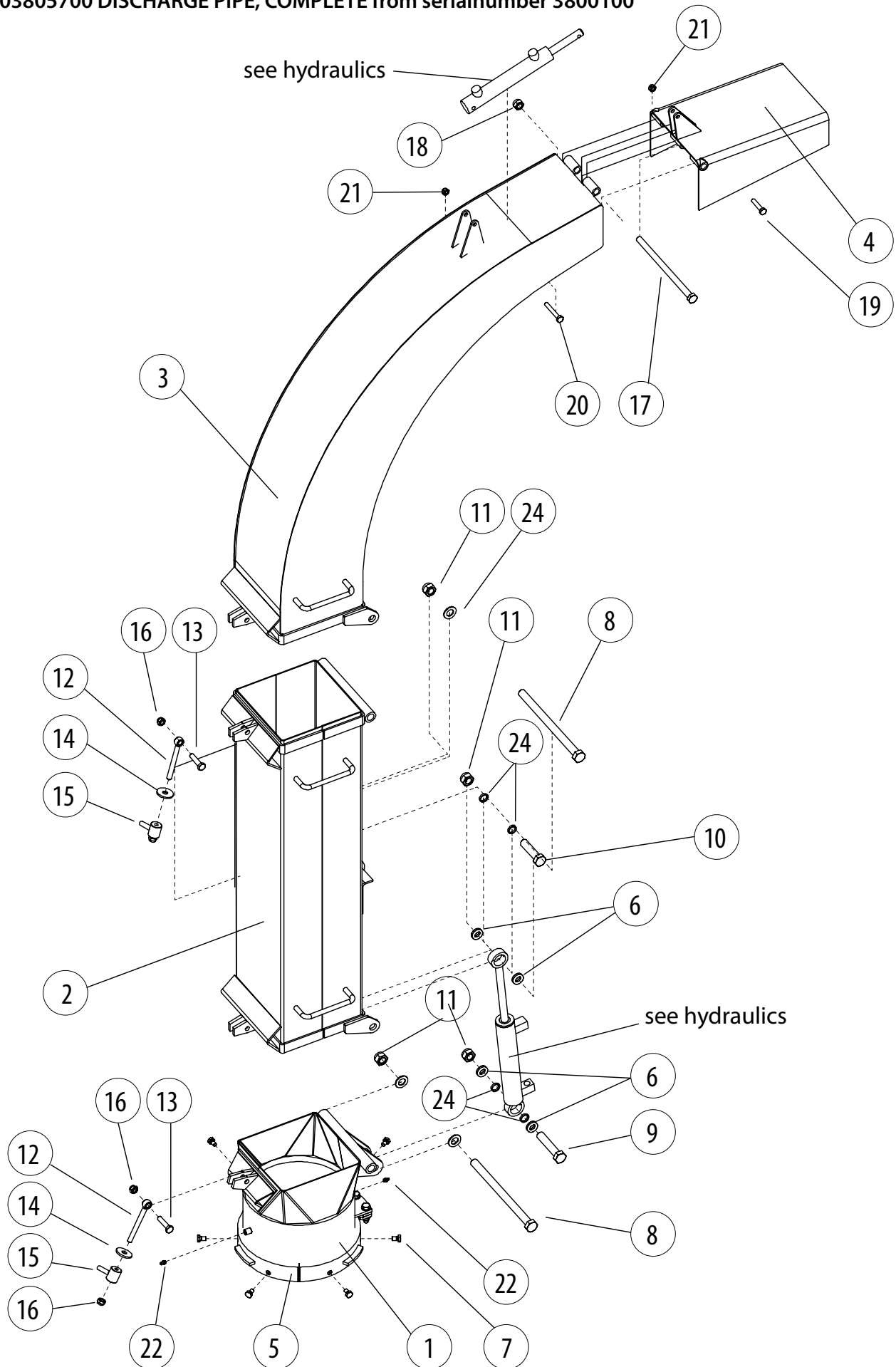



# FARMI 381 HFC / HF

03805700 DISCHARGE PIPE, COMPLETE from serialnumber 3800100

Part	Order no	Description	Remarks	Qty
1	33805710	Discharge chute rotation		1
2	33805740	Extension		1
3	33805770	Dicharge pipe		1
4	43805810	Vizor		1
5	43801430	Pair of locking flat iron		2
6	43800400	Bushing		4
7	52060209	Screw	M10X16 DIN933 88ZN	6
8	52063087	Screw	M20X300 DIN931 88ZN	2
9	52062262	Screw	M20x100 DIN931 88ZN	1
10	52062247	Screw	M20x70 DIN931 88ZN	1
11	52117207	Lock nut	M20 DIN985 8ZN	4
12	52062840	Eyebolt	M12X120 88ZN	2
13	52062627	Screw	M12X50 DIN931 88ZN	2
14	52200466	Washer	M12 DIN440 ZN	2
15	43489820	Hand lever		2
16	52117124	Lock nut	M12 DIN985 8ZN	4
17	52062783	Screw	M16X280 DIN931 88ZN	1
18	52117165	Lock nut	M16 DIN985 8ZN	1
19	52060266	Screw	M10X50 DIN931 88ZN	1
20	52060282	Screw	M10X70 DIN931 88ZN	1
21	52117108	Lock nut	M10 DIN985 8ZN	2
22	52401015	Grease nipple	AR1/8	2
23	03800090	Actuator for discharge chute rotation, complete	see separate spare part page	1
24	52200086	Washer	M20 DIN126 58ZN	4

# FARMI 381 HFC / HF

03800090 ACTUATOR FOR DISCHARGE CHUTE ROTATION, COMPLETE

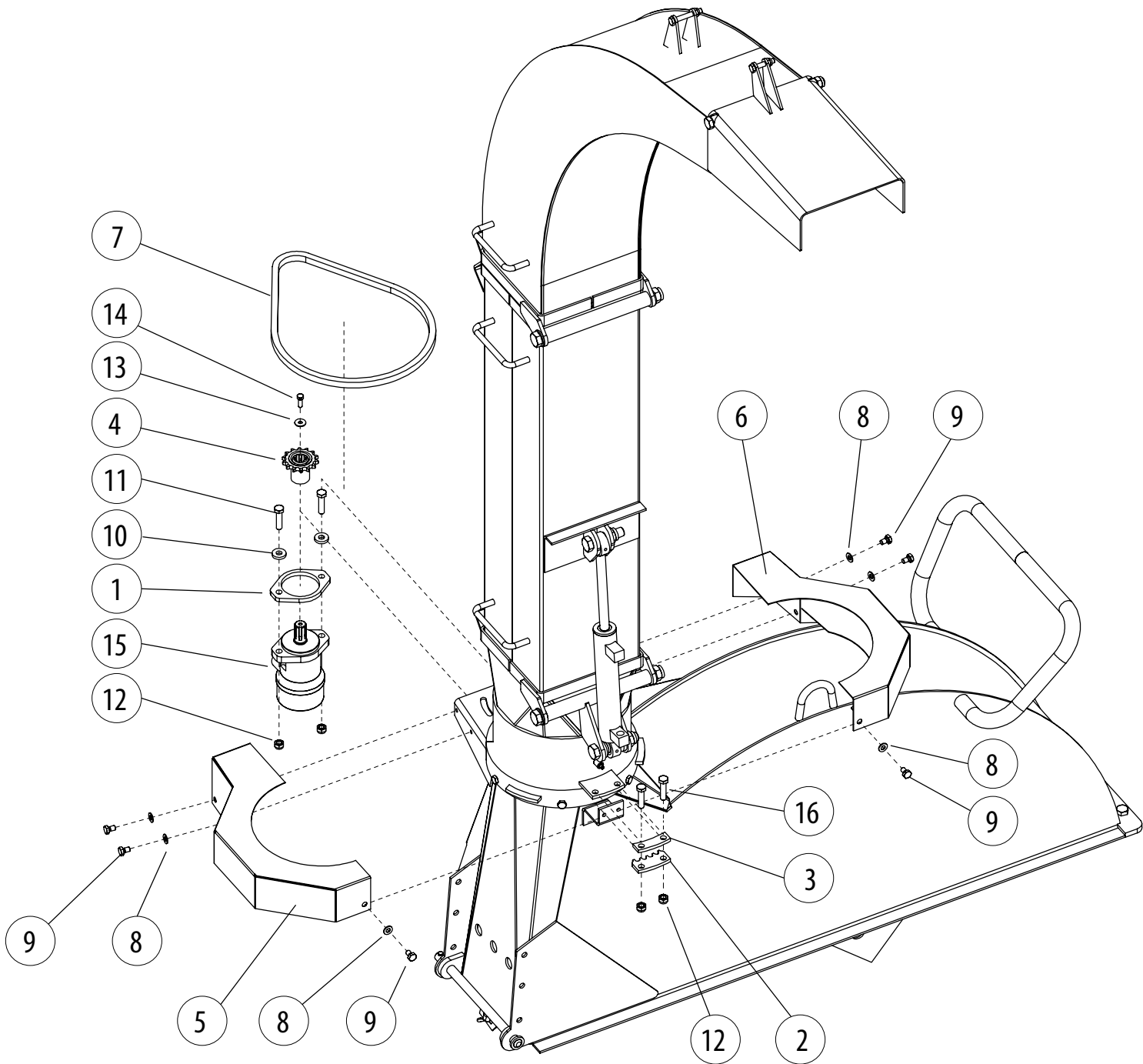

# FARMI 381 HFC / HF

## 03800090 ACTUATOR FOR DISCHARGE CHUTE ROTATION, COMPLETE

Part	Order no	Description	Remarks	Qty
1	43800820	Bottom flat iron for turn motor		1
2	43801400	Chain plate		1
3	43801410	Spacer plate		1
4	43801800	Splined shaft		1
5	43802530	Chain cover	right	1
6	43802540	Chain cover	left	1
7	54820014	Roller chain	5/8X83 LENKK DIN8187	1
8	52200045	Washer	M10 DIN125 58ZN	6
9	52060209	Screw	M10X16 DIN933 88ZN	6
10	52200490	Washer	M12 DIN 7349 ZN	2
11	52062627	Screw	M12X50 DIN931 88ZN	2
12	52117124	Lock nut	M12 DIN985 8ZN	4
13	52200235	Washer	M8 DIN9021 58ZN	1
14	52060175	Screw	M8X25 DIN933 88ZN	1
15	56001902	Hydraulic motor	OMP160	1
16	52062031	Screw	M12X40 DIN933 88ZN	2

# FARMI 381 HFC / HF

03801160 TWIG CRUSHER, COMPLETE

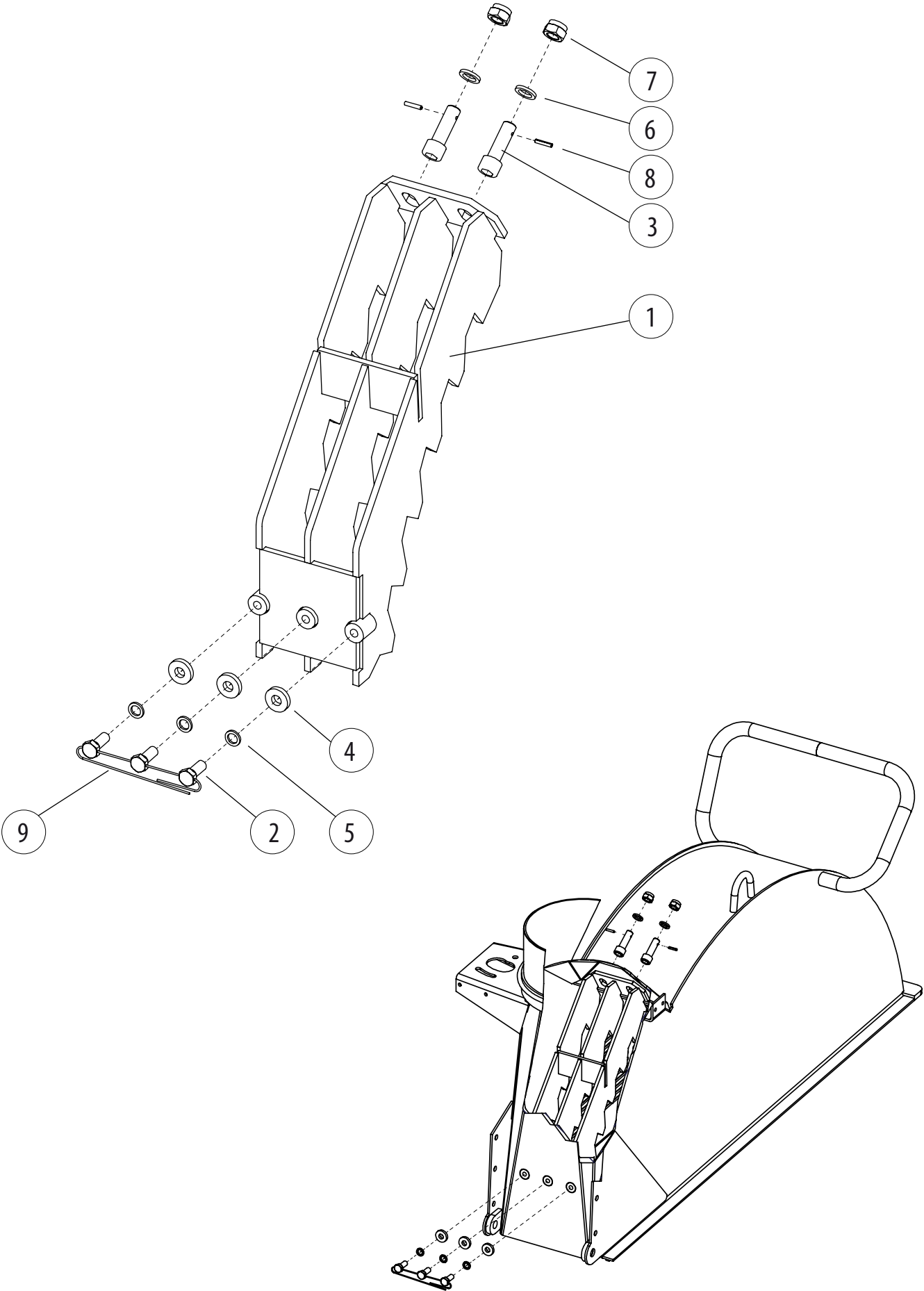

# FARMI 381 HFC / HF

---

## 03801160 TWIG CRUSHER, COMPLETE

Part	Order no	Description	Remarks	Qty
1	43801160	Twig crusher		1
2	43803550	Screw		3
3	43297680	Locking bolt		2
4	52200490	Washer	M12 DIN 7349 ZN	3
5	52214269	Lock washer	M12 NORD-LOCK	3
6	52214285	Lock washer	M16 NORD-LOCK	2
7	52117165	Lock nut	M16 DIN985 8ZN	2
8	52840071	Cotter pin	4X22 DIN1481	2
9	54929606	Iron wire	0,35 m	1

# FARMI 381 HFC / HF

HYDRAULIC FEEDER HF381 03800060

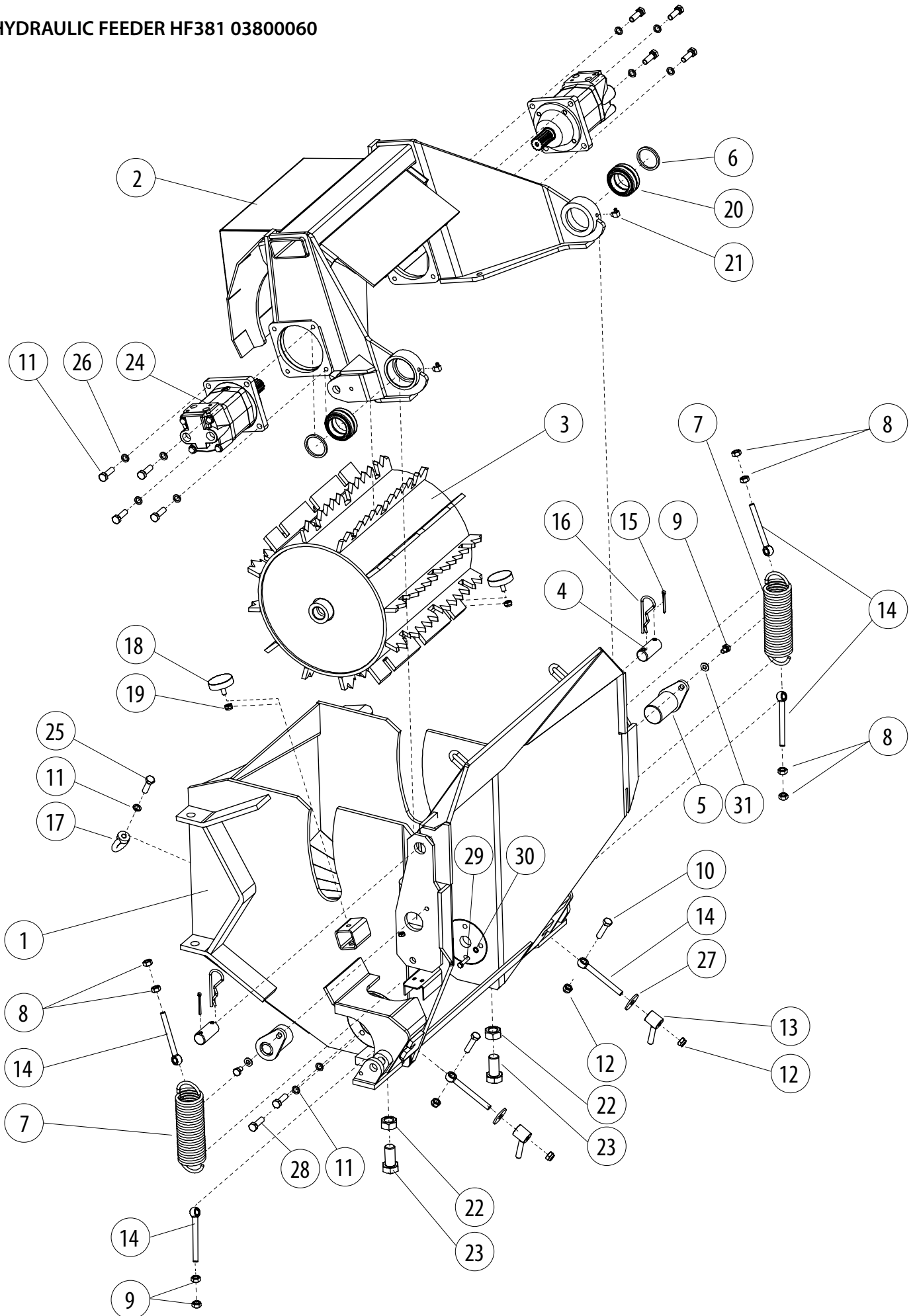

# FARMI 381 HFC / HF

## HYDRAULIC FEEDER HF381 03800060

Part	Order no	Description	Remarks	Qty
1	43802240	Frame		1
2	33802220	Roller's swing		1
3	43800410	Upper feed roller		1
4	43801960	Pin	L90	2
5	43501430	Pin	L78	2
6	43802490	Bushing		2
7	94617073	Tension spring		2
8	52110053	Nut	M12 DIN934 8ZN	8
9	52060209	Screw	M10X16 DIN933 88ZN	2
10	52062031	Screw	M12X40 DIN933 88ZN	2
11	52214269	Lock washer	M12 NORD-LOCK	11
12	52117124	Lock nut	M12 DIN985 8ZN	4
13	43489820	Hand lever		2
14	52062840	Eyebolt	M12X120 88ZN	6
15	52813151	Split pin	5X50 DIN94 ZN	2
16	52842143	Cotter	5X105	2
17	52091600	Eyebolt nut	M12 DIN582	1
18	54923080	Vibration isolation		2
19	52117108	Lock nut	M10 DIN985 8ZN	2
20	54592050	Articulation bearing		2
21	52401056	Grease nipple	CR1/8	2
22	52110103	Nut	M24 DIN934 8ZN	2
23	52062734	Screw	M24X50 DIN933 88ZN	2
24	56028860	Hydraulic motor	EPMSY-E W400-SH	2
24.1	58219759	Seal kit		2
25	52062973	Screw	M12X25 DIN933 88ZN	1
26	52063054	Screw	M10X40 DIN933 10.9ZN	8
27	52200466	Washer	M12 DIN440 ZN	2
28	52063592	Screw	M12X35 DIN933 10.9ZN	2
29	52060233	Screw	M10X30 DIN933 88ZN	4
30	52214251	Lock washer	M10 NORD-LOCK	4
31	52200045	Washer	M10 DIN125 58ZN	2

# FARMI 381 HFC / HF

FEED CHUTE HF380

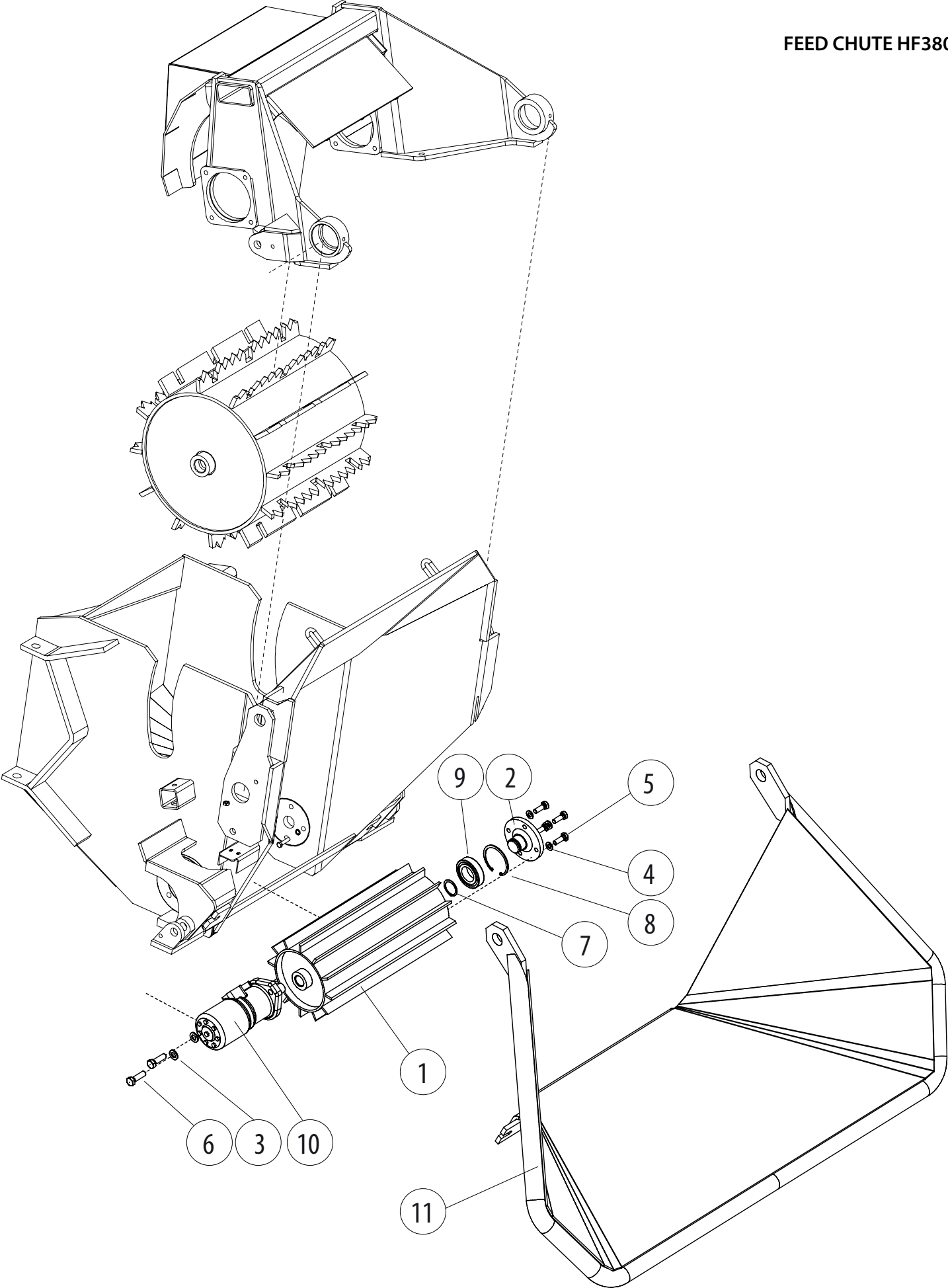



# FARMI 381 HFC / HF

## FEED CHUTE HF380

Part	Order no	Description	Remarks	Qty
1	43800350	Lower feed roller		1
2	43313048	Fastening for lower feed roller		1
3	52200052	Washer	M12 DIN125 58ZN	8
4	52200045	Washer	M10 DIN125 58ZN	6
5	52060233	Screw	M10X30 DIN933 88ZN	4
6	52063617	Srew	M12X40 DIN933 10.9MU	8
7	52230067	Circlip	35X2,5 DIN471	1
8	52231172	Circlip	72x2,5 DIN472	1
9	54511340	Slotted sealed ball bearing		1
10	56002033	Hydraulic motor	MR400	1
11	43801770	Feed chute		1

# FARMI 381 HFC / HF

## FEED CONVEYOR FC381

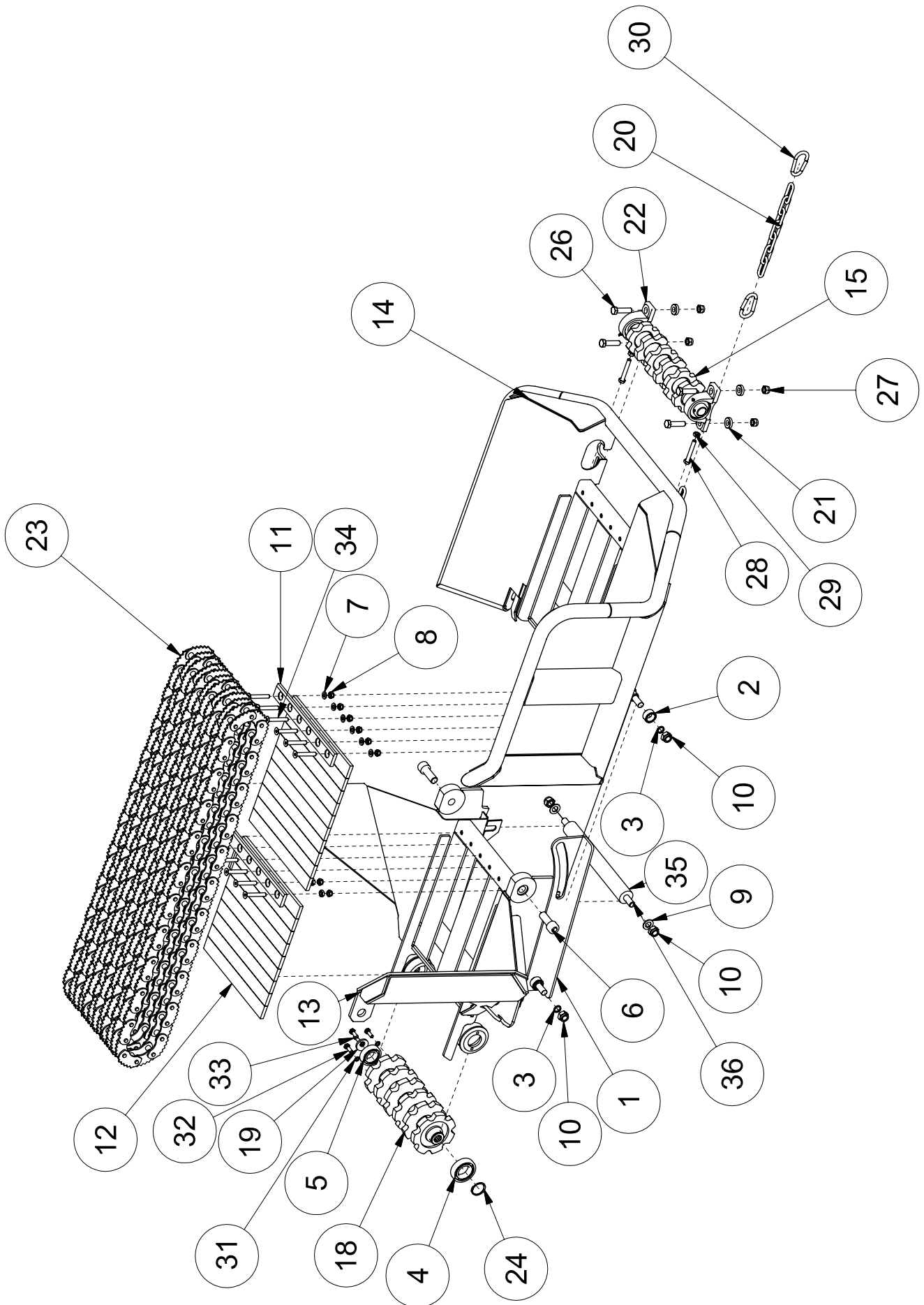

# FARMI 381 HFC / HF

## FEED CONVEYOR FC381

Part	Order no	Description	Remarks	Qty
1	43803920	Cylinder cover	left	1
2	43804810	Bushing		2
3	43800400	Bushing	D25X4,5	2
4	54512140	Ball bearing		1
5	54511340	Slotted sealed ball bearing		1
6	43803580	Screw	M24	2
7	52200052	Washer	M12 DIN125 58ZN	6
8	52117124	Lock nut	M12 DIN985 8ZN	12
9	52200086	Washer	M20 DIN126 58ZN	2
10	52117207	Lock nut	M20 DIN985 8ZN	4
11	43806520	Sliding surface		2
12	43806530	Sliding surface		9
13	33806900	Frame		1
14	33806600	Front frame		1
15	33805840	Front axle		1
16	33805940	Bearing housing	right	1
17	33805950	Bearing housing	left	1
18	33805870	Rear axle		1
19	43805960	Rear axle locking plate		1
20	43804850	Locking chain		1
21	43292739	Washer		4
22	54822850	Bearing unit	vertical	2
23	54828500	Feeding chain		6
24	52230257	Circlip	45x2,5 DIN471	1
25	52231172	Circlip	72x2,5 DIN472	1
26	52062130	Screw	M16X60 DIN931 88ZN	4
27	52117165	Lock nut	M16 DIN985 8ZN	4
28	52063340	Screw	M12X80 DIN933 88ZN	2
29	52110053	Nut	M12 DIN934 8ZN	2
30	53804136	Spring hook	DIN 5299C, 10X100	2
31	52214251	Lock washer	M10 NORD-LOCK	4
32	52060233	Screw	M10X30 DIN933 88ZN	4
33	52090750	Hexagon socket countersunk head cap screw	M10X30 DIN7991 88	1
34	52090740	Hexagon socket countersunk head cap screw	M12X80 10.9ZN DIN7991	12
35	43806540	Supporting roll		1
36	43806550	Supporting roll axle		1

# FARMI 381 HFC / HF

## HYDRAULICS

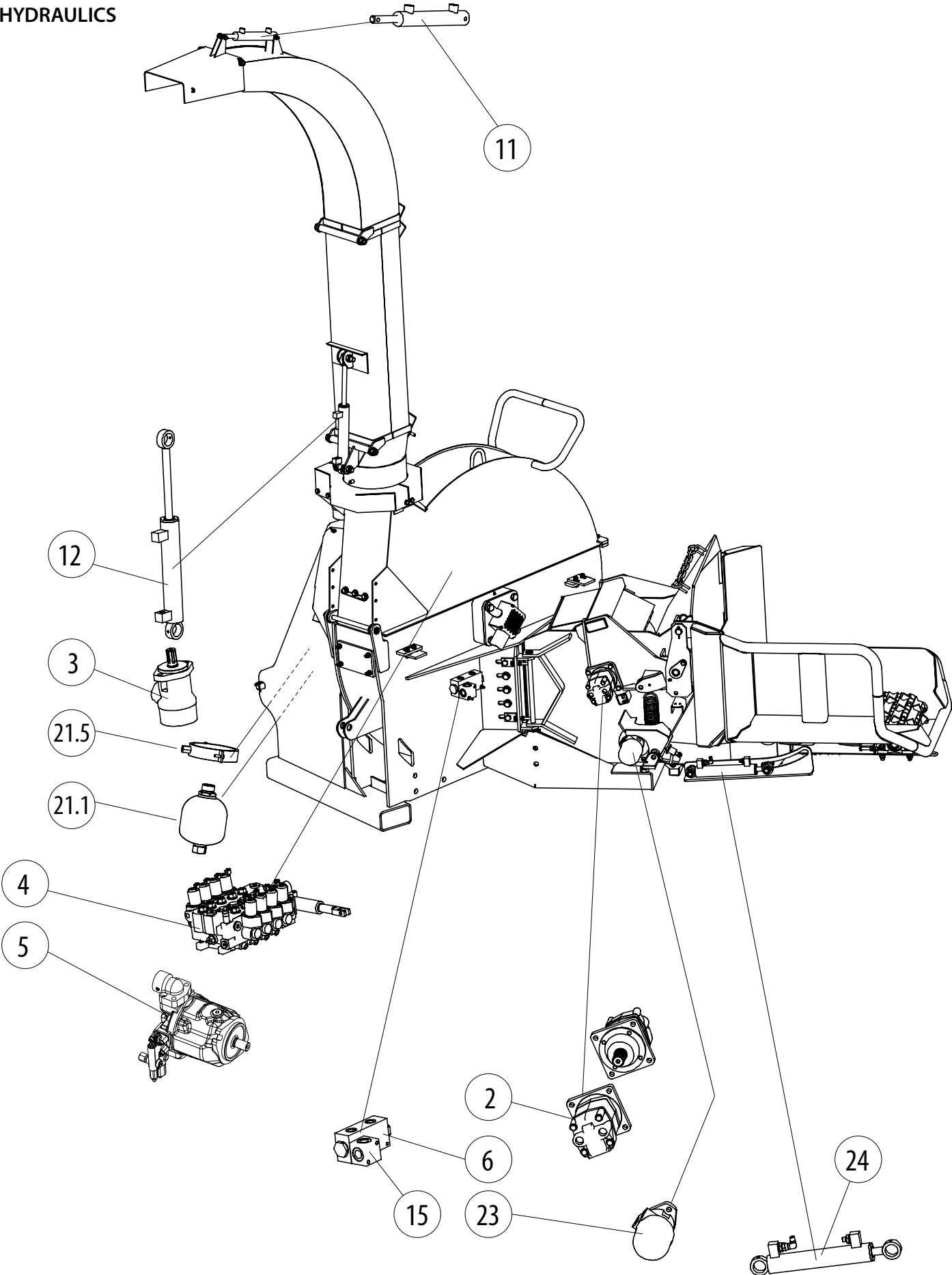

# FARMI 381 HFC / HF

## HYDRAULICS

Part	Order no	Description	Remarks	Qty
1	03806760	Hose series		1
2	56028860	Hydraulic motor	EPMSY-E W400-SH	2
2.1	58219759	Seal kit		1
3	56001902	Hydraulic motor	MP 160	1
3.1	58217746	Seal kit		1
4	56048410	Directional control valve		1
4.1	56048395	Solenoid valve	12VDC	8
4.2	56048360	Tie rod kit		1
4.3	58103540	Seal kit	solenoid valve	1
4.4	52358030	Seal kit	between valve blocks	1
5	56057390	Hydraulic double pump		1
6	56040744	Flow divider		1
-	-	-	-	-
8	56070261	Throttle valve		2
-	-	-	-	-
10	56072180	Counter valve		1
11	56097793	Hydraulic cylinder	32/20-150	1
11.1	52355510	Seal kit		1
12	56016040	Hydraulic cylinder	40/20-200, double acting	1
12.1	56016045	Seal kit		1
13	56091648	Hydraulic cylinder	18-94 L=166	1
14	43442433	Nipple	R1/4"-R1/4"	2
15	56620727	Coupling	X1 3/4 L55	1
16	44093360	Fitting part	RK 1"	1
17	40140345	Sticker	arrow	2
18	52435807	Gauge fitting	R3/8-R1/2-R1/4	1
19	52435050	Swivel fitting		1
20	52435831	Gauge fitting	R3/4-R1/4-R3/4	1
21	03810240	Pressure accumulator	complete, 380HF + 380HFC	1
21.1	56010690	Pressure accumulator		1
21.2	52437019	Swivel fitting	UK R1/2"-SK R3/4"	1
21.3	52444007	T-fitting	R 3/4"	1
21.4	52442183	Angle nipple	R 3/4"	1
21.5	54916450	Tube clamp		1
21.6	56533094	Hose assy	V3/4"S L=0,7 m	1

# FARMI 381 HFC / HF

## HYDRAULICS

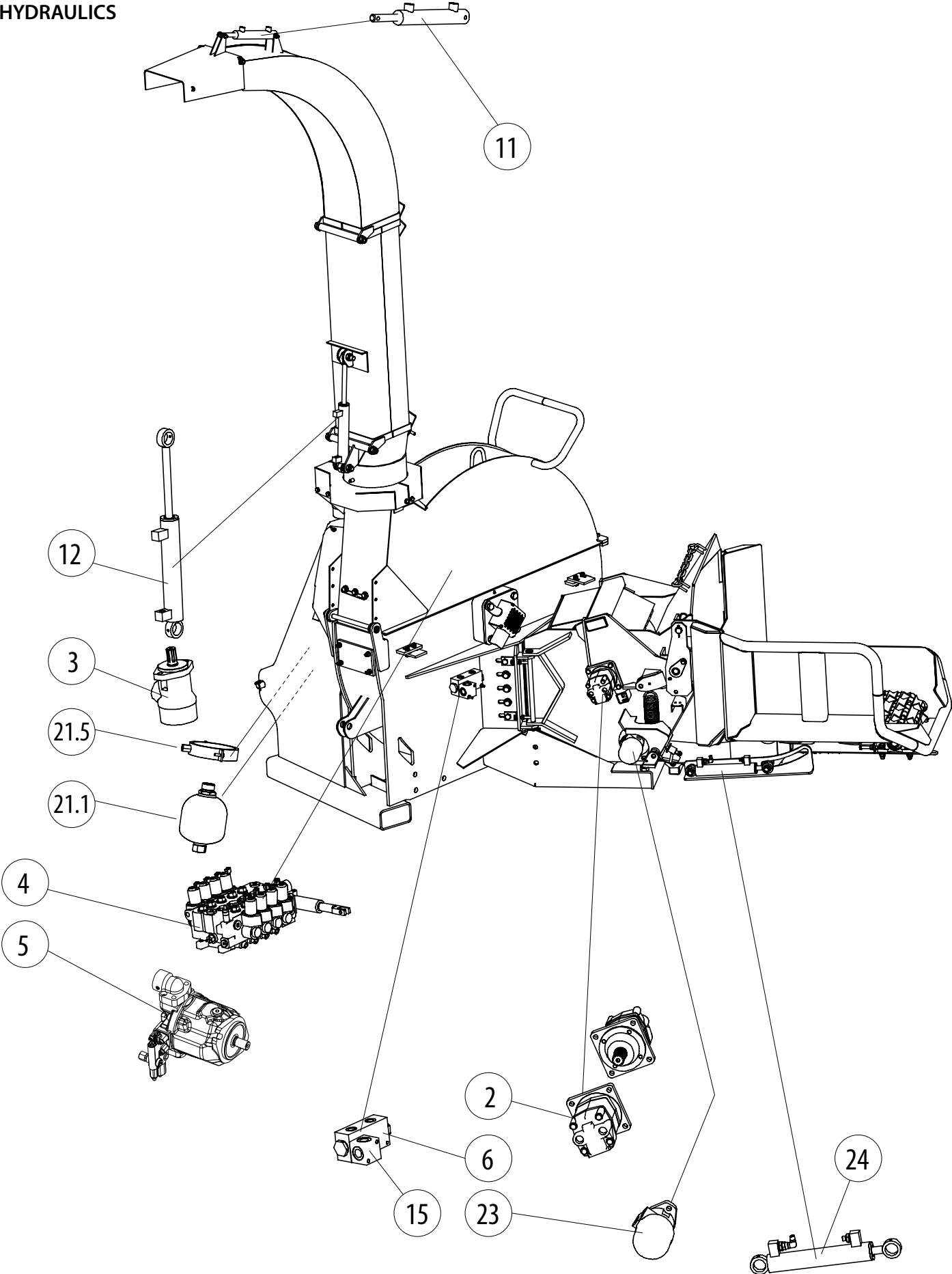

# FARMI 381 HFC / HF

## HYDRAULICS

Part	Order no	Description	Remarks	Qty
HYDRAULICS FC381				
22	03809020	Hose series		1
22.1	56516438	Hose assy	S1/4"S L=4,6 m	1
22.2	56518426	Hose assy	S1/4"K L=4,4 m	1
23	56002020	Hydraulic motor	MR 250 SH D	1
24	56016040	Hydraulic cylinder	40/20-200, double acting	1
24.1	56016045	Seal kit		1
25	56070261	Throttle valve		1
26	52432051	Double fitting	R1/2	2
27	52432119	Double fitting	R1/4-3/8	2
28	52442761	Angle nipple	R1/4 04510-04 90°	1
29	52432101	Double fitting	R1/4	1
30	52432226	Double fitting	R1/4-1/2	2
31	52449022	Quick fitting	1/2" SK	2
32	54922141	Cap	1/2"	2
33	52391034	Usit-ring	U13,74x20,57x2,03	2
34	52390200	Usit-ring	U21,54X28,58X2,49	4
35	52390556	Usit-ring	U17,28X23,8X2,03	2

# FARMI 381 HFC / HF

HOSE SERIES: DIRECTIONAL CONTROL VALVE FROM ABOVE

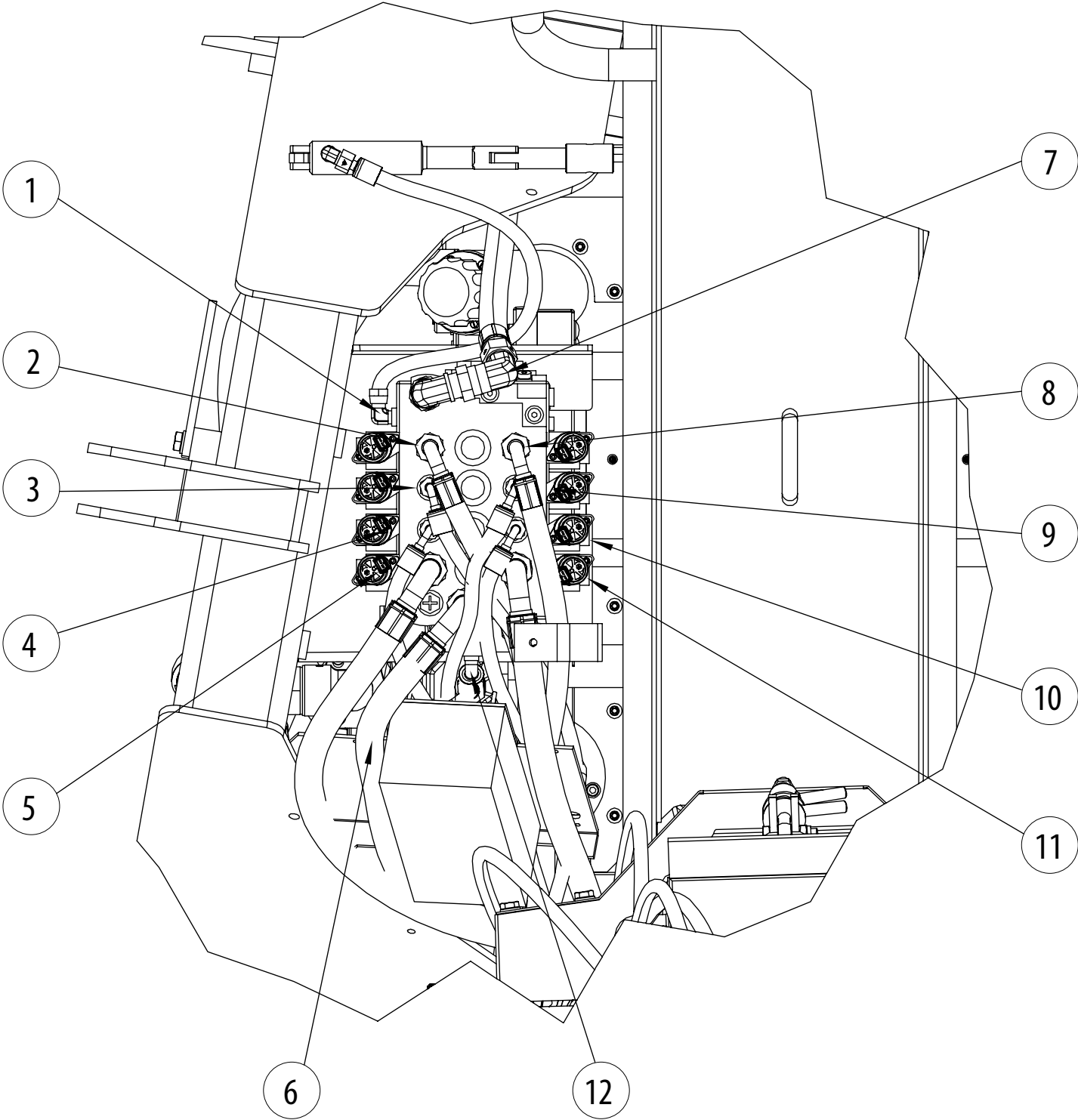



# FARMI 381 HFC / HF

## HOSE SERIES: DIRECTIONAL CONTROL VALVE FROM ABOVE

Part	Order no	Description	Remarks	Qty
1	56518111	Hose assy, K1/4"S L=0,8 m	Support cylinder	1
2	56526288	Hose assy, K1/2"S L=2,3 m	Feed roller relief	1
3	56518228	Hose assy, K1/4"S L=1,7 m	Discharge pipe swivel to the left	1
4	56518430	Hose assy, S1/4"K L=4,6 m	Upward lid movement	1
	56518111	Hose assy, K1/4"S L=0,8 m		1
5	56534274	Hose assy, K3/4"S L=2,2 m	feed	1
6	56534142	Hose assy, K3/4"S L=0,95 m	P2, accumulator valve	1
7	56533094	Hose assy, V3/4"S L=0,7 m	T3, return filter	1
8	56526288	Hose assy, K1/2"S L=2,3 m	Feed roller pressure loading	1
9	56518228	Hose assy, K1/4"S L=1,7 m	Discharge pipe swivel to the right	1
10	56518430	Hose assy, S1/4"K L=4,6 m	Downward lid movement	1
	56518111	Hose assy, K1/4"S L=0,8 m		1
11	56534274	Hose assy, K3/4"S L=2,2 m	reverse	1
12	56518111	Hose assy, K1/4"S L=0,8 m	LS pump - valve	1

# FARMI 381 HFC / HF

## HOSE SERIES: PUMP HOSES

After a long machine downtime, the pump must be replenished via the nipple of the leakage line!

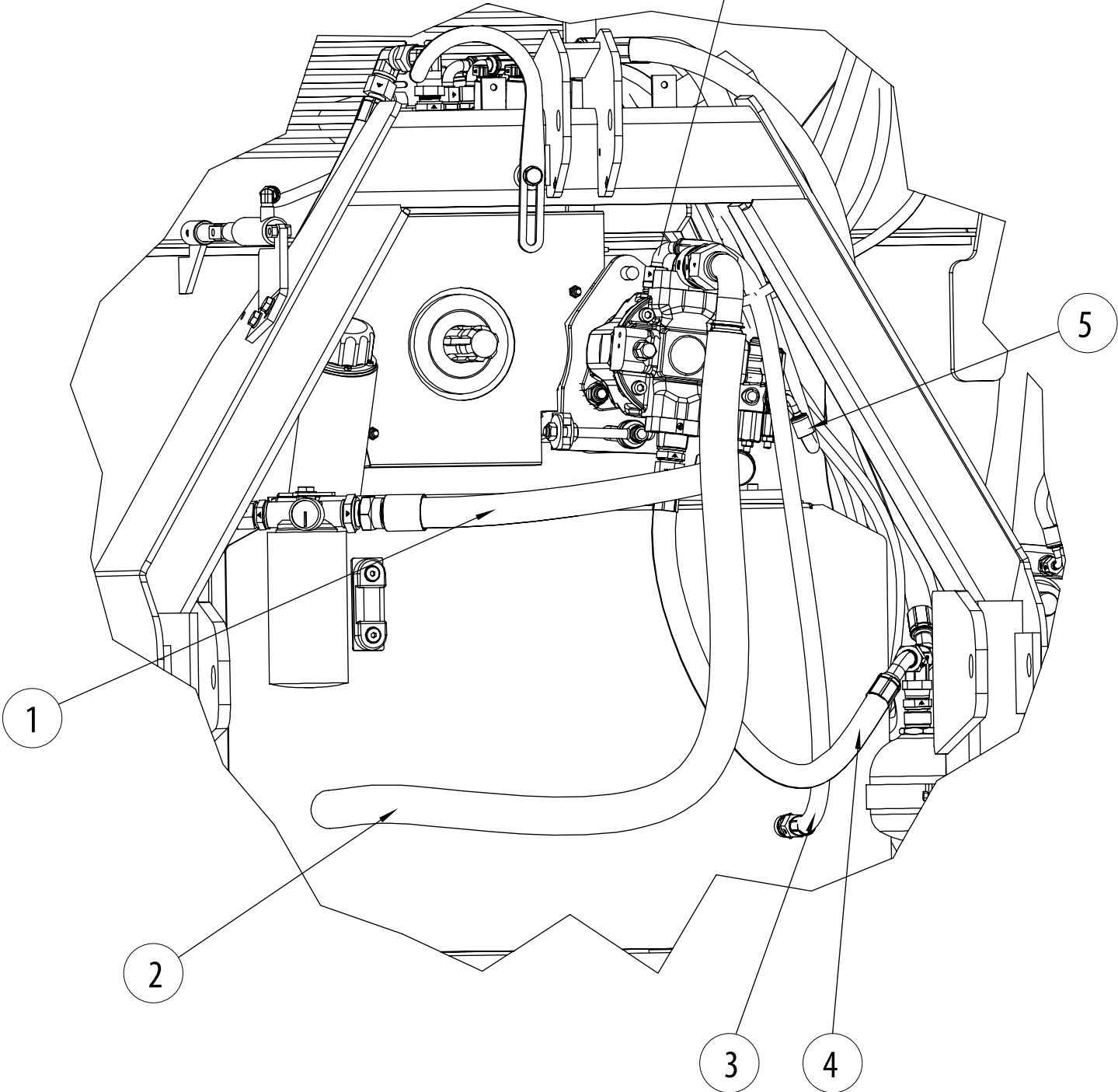

# FARMI 381 HFC / HF

---

## HOSE SERIES: PUMP HOSES

Part	Order no	Description	Remarks	Qty
1	56500077	Hose assy, S1"S L=0,6 m	return oil filter - tank	1
2	54921382	Intake hose, 1 1/4" L=1,05 m, 5 bar	tank - pump	1
3	56526148	Hose assy, K1/2"S L=0,950 m	leakage line, pump - tank	1
4	56533094	Hose assy, V3/4"S L=0,7 m	pump - pressure accumulator	1
5	56518111	Hose assy, K1/4"S L=0,8 m	LS pump - valve	1

# FARMI 381 HFC / HF

## HOSE SERIES: FRONT HOSES

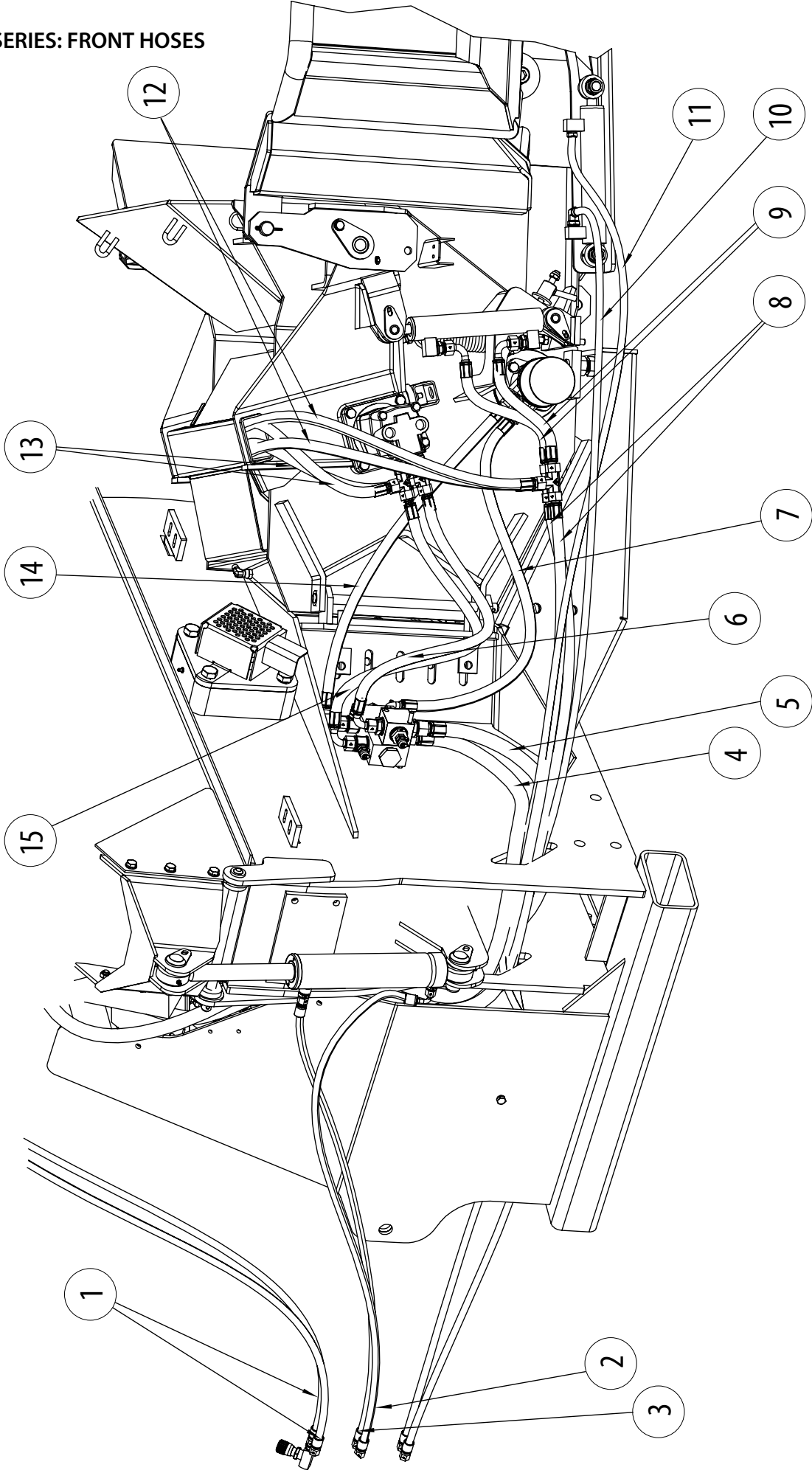

# FARMI 381 HFC / HF

## HOSE SERIES: FRONT HOSES

Part	Order no	Description	Remarks (TR=tractor)	Qty
1	56516388	Hose assy, S1/4"S L=3,6 m	(TR) Discharge pipe falling	2
2	56518327	Hose assy, K1/4"S L=2,7 m	(TR) Opening the upper housing	1
3	56516305	Hose assy, S1/4"S L=2,5 m	(TR) Closing the upper housing	1
4	56534274	Hose assy, K3/4"S L=2,2 m	Pressure of the feed motors	1
5	56534274	Hose assy, K3/4"S L=2,2 m	Return hose of the of the feed motors	1
6	56526148	Hose assy, K1/2"S L=0,95 m	Return hose of upper hydraulic motors	1
7	56526148	Hose assy, K1/2"S L=0,95 m	Return hose of lower hydraulic motor	1
8	56526288	Hose assy, K1/2"S L=2,3 m	Relief / pressure loading of the feed roller	2
9	56526031	Hose assy, K1/2"S L=0,4 m	Relief / pressure loading of the feed roller	2
10	56518126	Hose assy, K1/4"S L=0,85 m	(TR) Upward conveyor movement	1
11	56516438	Hose assy, S1/4"S L=4,6 m	(TR) Downward conveyor movement	1
12	56526304	Hose assy, K1/2"S L=2,5 m	Relief / pressure loading of the feed roller	2
13	56525173	Hose assy, V1/2"S L=1,2 m	Upper hydraulic motor	2
14	56526114	Hose assy, K1/2"S L=0,8 m	Pressure of the lower hydraulic motors	1
15	56526148	Hose assy, K1/2"S L=0,95 m	Pressure of the upper hydraulic motors	1

# FARMI 381 HFC / HF

## HYDRAULICS CIRCUIT DIAGRAM

MR 250 (HFC)  
 MR 400 EPMSY-EEPMSY-E  
 W 400 W 400  
 32/20-150  
 L=280

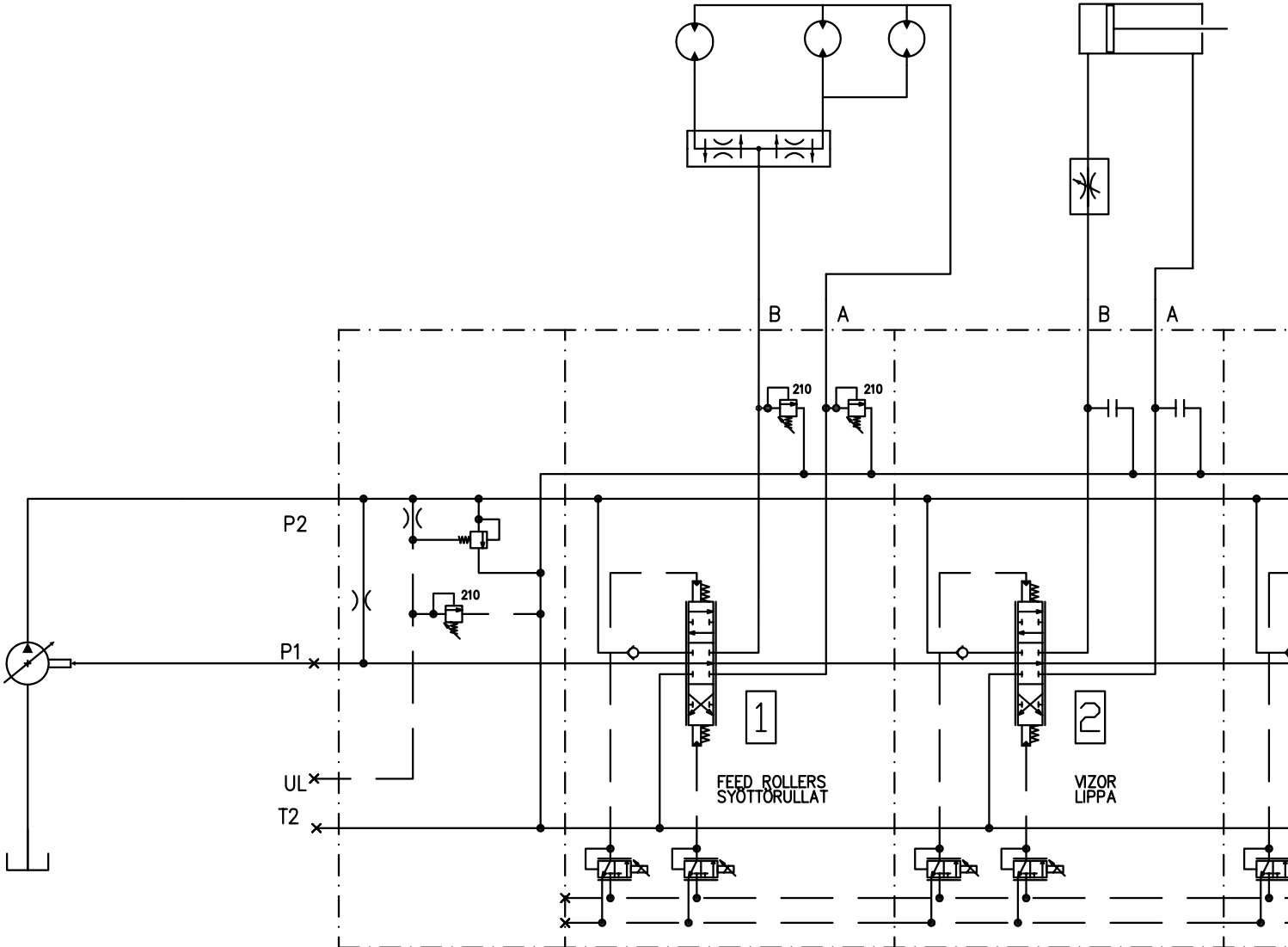

# FARMI 381 HFC / HF

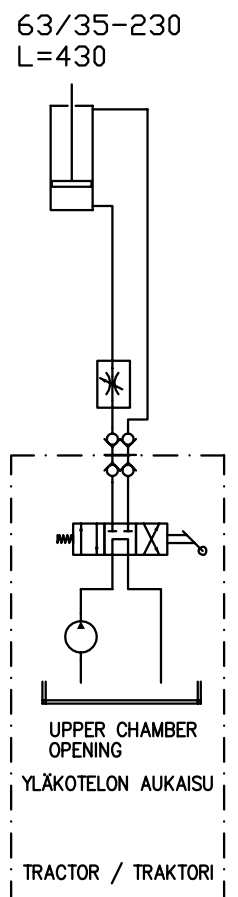
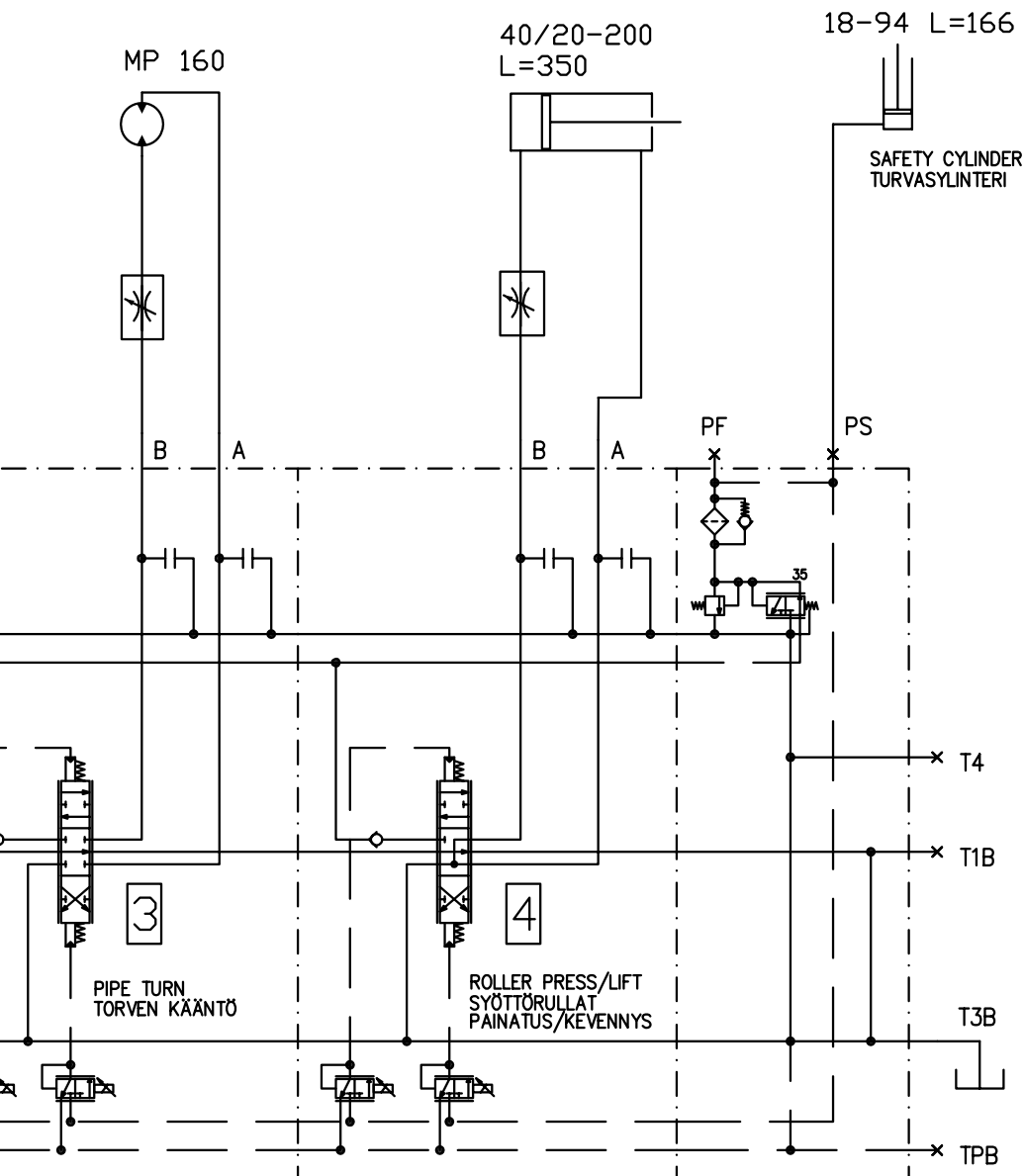





---

## WARRANTY

Farmi Forest Oy grants a 12-month warranty on all of its products, covering material and manufacturing faults. The warranty comes into effect on the product's delivery date.

The manufacturer is not liable for damages caused by:

- misuse of the product
- alterations or repairs made without the manufacturer's permission
- insufficient maintenance
- non-original parts

The warranty does not cover wearing parts.

Send faulty parts, carriage paid, to the manufacturer for inspection. Repairs will be conducted by Farmi Forest Oy or an authorized expert. The warranty is valid only if the bottom part of this page is filled in and returned to the manufacturer within 30 days of receipt of the product. By returning the warranty certificate, you confirm that you have read and understood the instruction manual that came with the product.



Farmi Forest Corporation  
Ahmolantie 6  
FIN-74510 IISALMI  
FINLAND

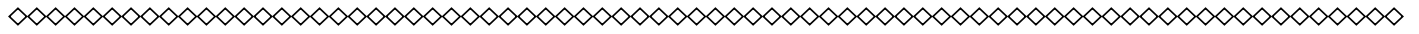

## PRODUCT REGISTRATION FORM

Date of delivery: \_\_\_\_/\_\_\_\_ 20\_\_\_\_

Dealer:

Dealer's address:

Dealer's tel:

Product and type:

Serial number:



Return to the manufacturer

Date of delivery: \_\_\_\_/\_\_\_\_ 20\_\_\_\_

Dealer:

Dealer's address:

Dealer's tel:

Customer:

Customer's address:

Customer's tel:

E-mail:

Product and type:

Serial number:

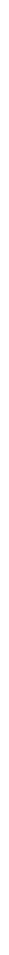





Farmi Forest Corporation  
Ahmolantie 6  
FIN-74510 Iisalmi, Finland  
Puh. +358 (0)17 83 241  
Fax. +358 (0)17 8324 372  
[www.farmiforest.fi](http://www.farmiforest.fi)